

**Resource IV.**  
**The Four Position Foundation:**  
**“Love and Beauty” and**  
**“Cheonjeong-天情 and Hyojeong-孝情”**

① “I would like to tell you about the way of life in the Unification Church. The core of our philosophy, the Divine Principle, is directly linked to the Shimjeong of God, who is the center of the universe.” (September 11, 1977)

1

② “I strive to practice the course of restoration centered on the Divine Principle. If you want to know the depth of my Shimjeong—the bone marrow of life—you need to go down deep, just like roots of a tree. ... If you want to grow a big branch, you must be strong enough to suck up nutrients deep down in the roots.” (August 1, 1971)

2

# I. "Love and Beauty"

R-4

1. Through understanding "Give and Receive Action" we can understand "Love and Beauty"

① "Through the agency of universal prime energy, the subject and object elements of every entity form a common base and enter into interaction. This interaction, in turn, generates all forces the entity needs for existence, multiplication and action. The interaction generating these forces through this process is called give and receive action." (Divine Principle. pg. 35)

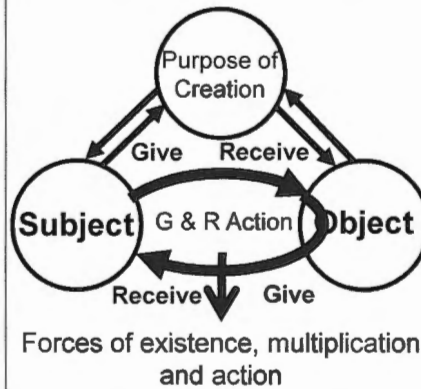

② "I think the most important field of research is about the concept of harmony." (1977.9.11)

3

Then, what does it mean "form a common base and enter into interaction (= giving-well and receiving-well?). It means that the two parties give and receive to benefit each other, rather than give for the sake of receiving.

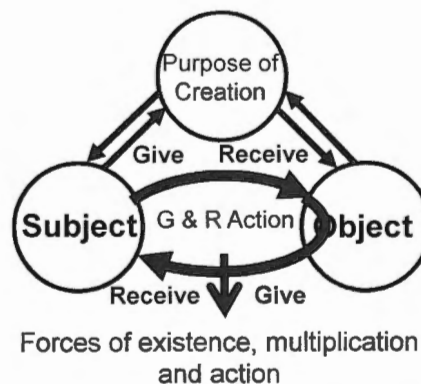

The subject partner gives to the object partner unselfishly with Jeongseong, and the object partner, in turn, appreciates and receives that Jeongseong deeply. The object partner then gives back to the subject partner, and this results in the subject partner's appreciation of the object partner's Jeongseong.

4

## 2. Through understanding "Origin-Division-Union Action" <sup>R-4</sup> we can understand "Love and Beauty"

① "This whole process—in which God, the Origin, and two entities are separately manifested and reunited in oneness—is called origin-division-union action." (Divine Principle, pg. 37)

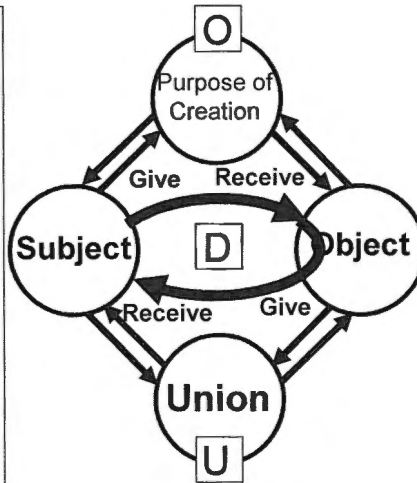

All beings have a prepared subject partner and a prepared object partner (or an already formed common base), and they reunite in oneness with a purpose, accordingly, through give and receive action. This process is called origin-division-union action. 5

## 3. Definition of Love and Beauty <sup>R-4</sup>

① "When two entities, discrete manifestations of God's dual characteristics, form a common base and seek to reunite as the third object partner to God and establish a four position foundation, they will engage in give and receive action.

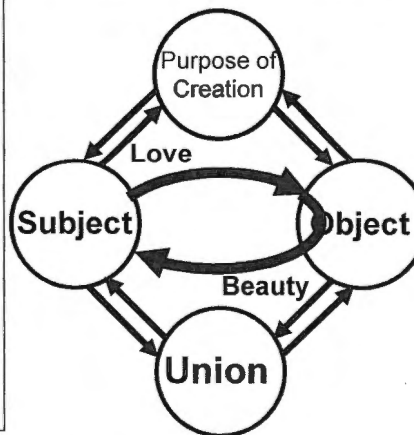

In accomplishing this, the emotional force that the subject partner gives to the object partner is called love, and the emotional force the object partner returns to the subject partner is called beauty." (Divine Principle, pg. 47)

According to this definition, not all the emotional power given by the subject partner to the object partner is love. Love creates the four position foundation for God's purpose of creation. Love is the emotional power given by the subject partner to the object partner in order to create oneness that brings joy to God. 6

Also, love is the emotional force that the object partner gives to the subject partner. When receiving love, the object partner gives back love and emotional force, to the subject partner.

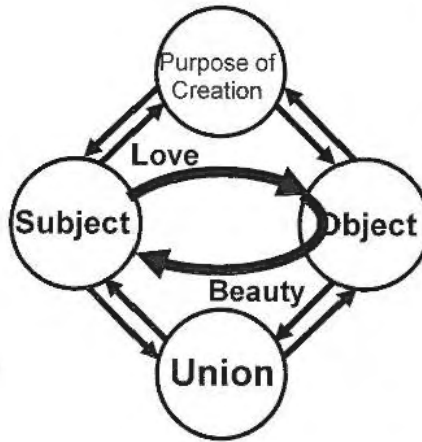

Both love and beauty are emotional forces given to the other partner. The object partner's love given in response to the subject partner's love is called beauty.

② "In the relationship between God and human beings, God gives love as the subject partner and human beings return beauty as object partners. In the relationship between a man and a woman, the man is the subject partner, giving love, while the woman is the object partner, returning beauty. In the universe, people are the subject partners who give love to the natural world, and the natural world returns beauty as the object partner. ...

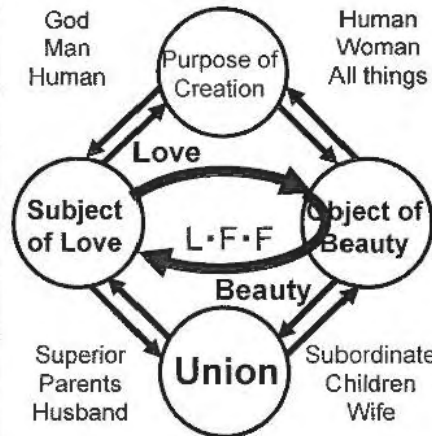

\*L·F·F = Loyalty, Filial Piety, Fidelity  
*Based on true love*

In interpersonal relationships, the beauty that a subordinate returns in response to the love of the superior is called loyalty, and the beauty that children return in response to the love of their parents is called filial piety. The beauty that a wife returns in response to the love of her husband is called fidelity." (Divine Principle, pg. 48)

**4. The difference between previously known definitions and the Divine Principle definitions: Loyalty and Filial Piety** R-4

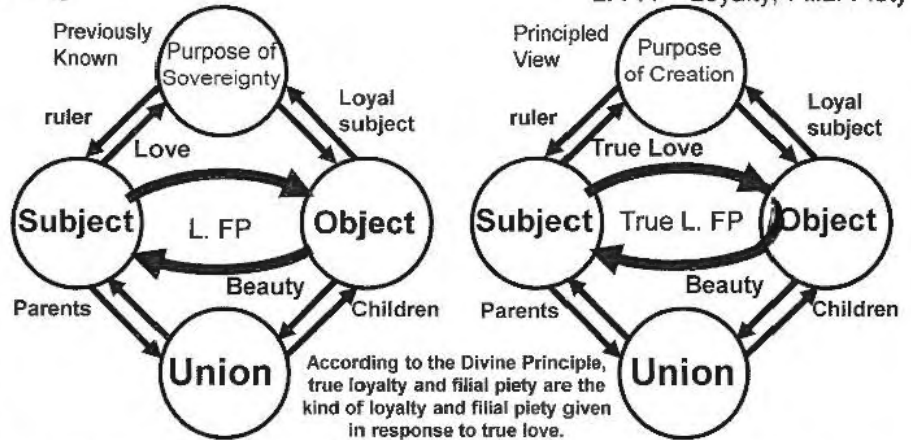

① "All 'true' things exist in the realm of Shimjeong, or love of original creation. We say a 'child of true filial piety' in relation to the original love that God intended." (Blessed Family and the Ideal Kingdom I, pg. 273)

**5. Love of Vertical Order and Love of Horizontal Order** R-4

The relationship between God and humans as well as the relationship between parents and children are vertical.

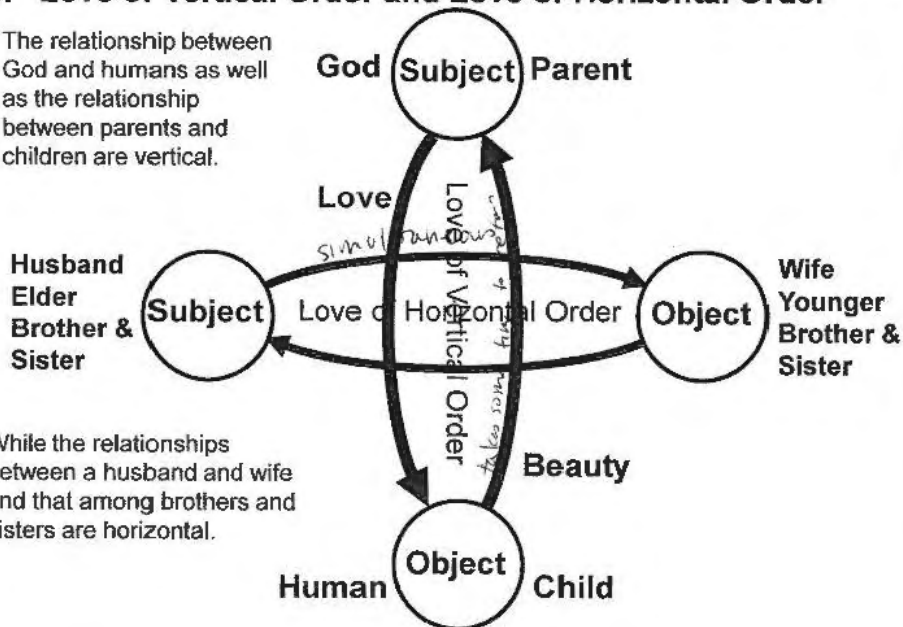

While the relationships between a husband and wife and that among brothers and sisters are horizontal.

## 6. Heavenly Jeong and Hyo Jeong

R-4

The emotional force given by God to humans is God's love. We call this Cheon (heavenly) Jeong.

We humans offer emotional force, or love, to God as his children, and this is our beauty.

忠孝心情  
Cheon Jeong

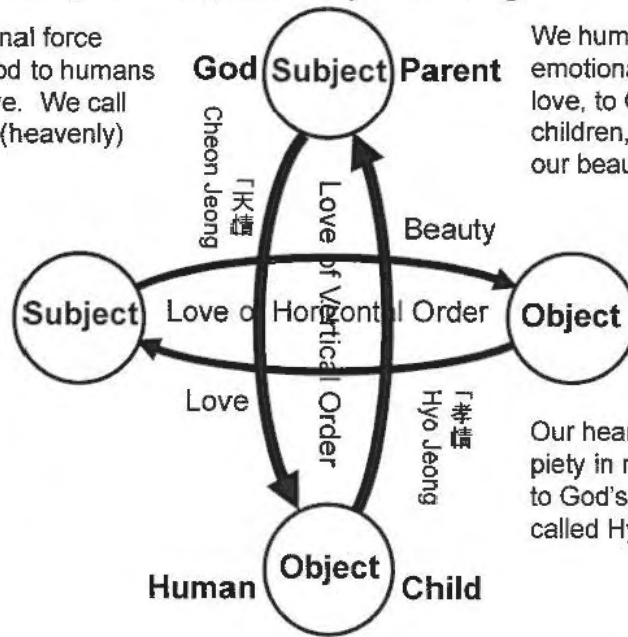

Our heart of filial piety in response to God's love is called Hyo Jeong.

11

Cheon Jeong and Hyo Jeong, therefore, are parallel to love and beauty between God and humans.

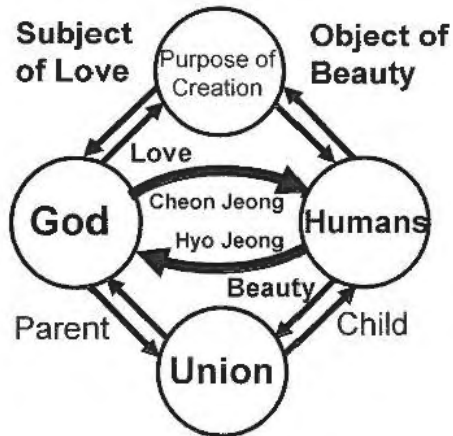

R-4

12

① "I am not a nationalist. The Second Advent's life is centered on Shimjeong of the heavenly kingdom. ... Heavenly Shimjeong goes beyond nations. All saints, therefore, think globally. ... Heaven is thought of as Universal and transcends ideas of boundaries. Heavenly Shimjeong starts from the point where you go beyond nations. Our foundation is made when heavenly Shimjeong of good sovereignty, overcoming evil sovereignty, merges with earthly Shimjeong. Although you have followed me so far, you did not necessarily become connected to heavenly Shimjeong on the foundation of national victory. Those who search for heavenly Shimjeong are remembered by Heaven, while those who search for human emotion remain at the human level."  
(May 9, 1972).

13

## 7. The meaning of "love within beauty and beauty within love"

R-4

① "When the subject partner and object partner become completely one in harmony, love is found within beauty and beauty is found within love."

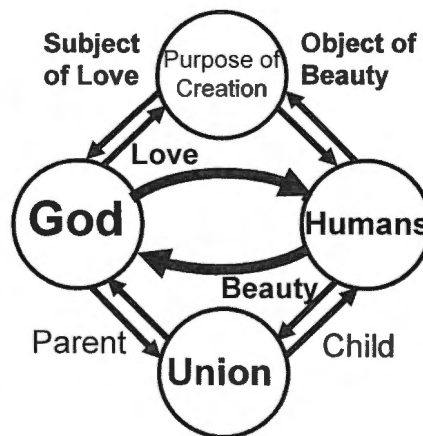

This is because when a subject partner and object partner become one in a circular movement, the subject partner sometimes acts as an object partner, and the object partner sometimes acts as a subject partner."  
(Divine Principle. pg. 48)

14

A. "... the emotional force that the subject partner gives to the object partner is called love." (Divine Principle pg. 48)

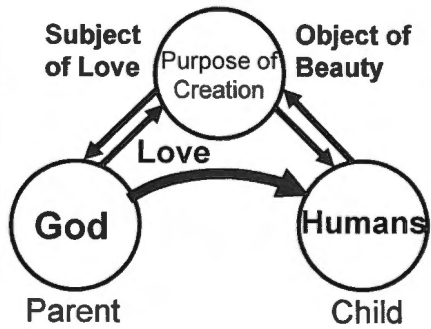

① "What kind of parents are True Parents? They love their children forever with no end." (May 1, 1983)

② "The basic rule is that parents think of themselves only after they take care of their children. They love their children first before loving themselves." (August 16, 1985)

③ "The heart of parents is to give and forget all. ... They feel sorry that they cannot give more." (November 15, 1970)

④ The Bible says, "What I have said, that I will bring about; what I have planned, that I will do." (Isaiah 46:11)

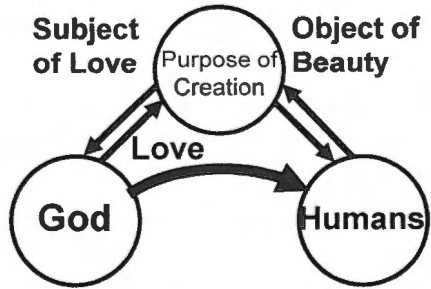

⑤ The Bible says, "Even to your old age and gray hairs I am he, I am he who will sustain you. I have made you and I will carry you; I will sustain you and I will rescue you." (Isaiah 46:4)

⑥ "God has never forgotten His purpose of saving this world." (January 1, 1977)

⑦ "I revealed myself to those who did not ask for me; I was found by those who did not seek me. To a nation that did not call on my name, I said, 'Here am I, here am I.'" (Isaiah 65:1)



⑧ "The heart of parents can never curse children. Even when carrying a cross, the parent looks for a way to save children. By the same token, I went and carried every cross so you can live."  
(October 19, 1970)

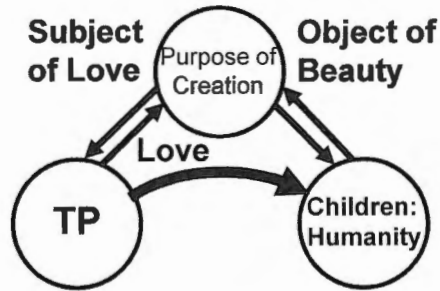

⑨ "Since God is a parent, when He thinks about His son who is going to the execution place, He wants to find any kind of method to forgive and release him."  
(Belvedere, 1984.7.10)

⑩ "So God created humankind in His own image, in the image of God He created them; male and female He created them.

God blessed them and said to them, "Be fruitful and increase in number; fill the earth and subdue it. Rule over the fish in the sea and the birds in the sky and over every living creature that moves on the ground." (Genesis 1:27-28)

God's Love up until the end of the whole process of creation (up until the creation of human beings)

⑪ The Bible says, "But the Lord God called to the man, 'Where are you?' ... 'Have you eaten from the tree that I commanded you not to eat from?'" (Genesis 3:9-11)

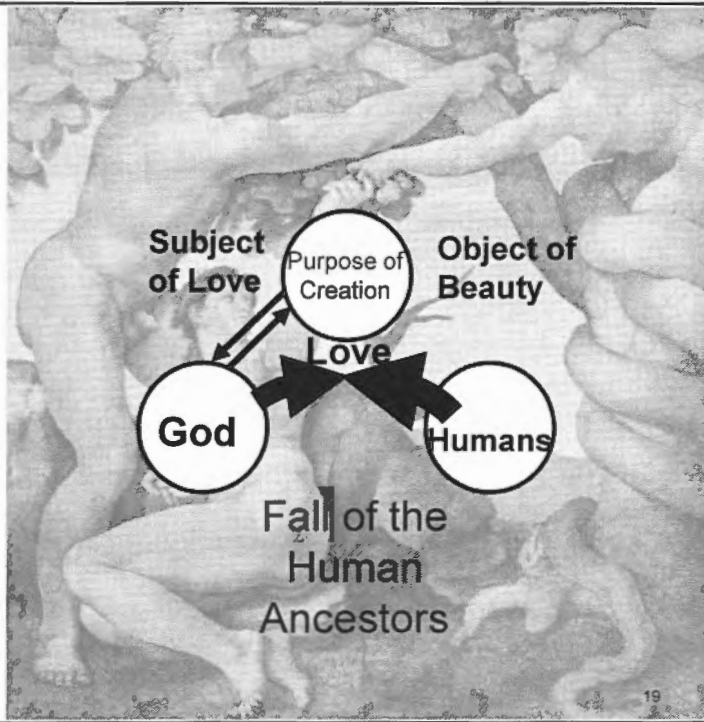

⑫ The Bible says, "And God saw that the wickedness of man was great in the earth, and that every imagination of the thoughts of his heart was only evil continually. And it repented the LORD that He had made man on the earth, and it grieved Him at His heart." (Genesis 6:5-6)

R-4

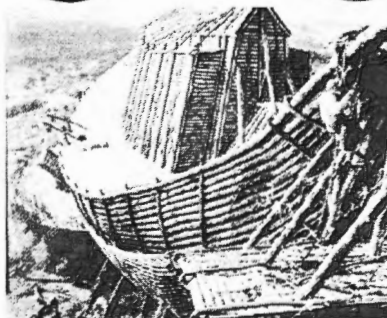
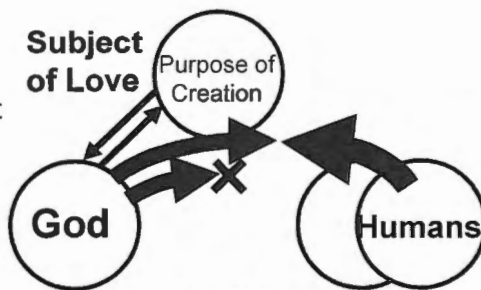

Failure of the Providence of Noah's Family

20

⑬ The Bible says, "The Lord said to Moses, "How long will these people treat me with contempt? How long will they refuse to believe in me, in spite of all the signs I have performed among them?" (Numbers 14:11)

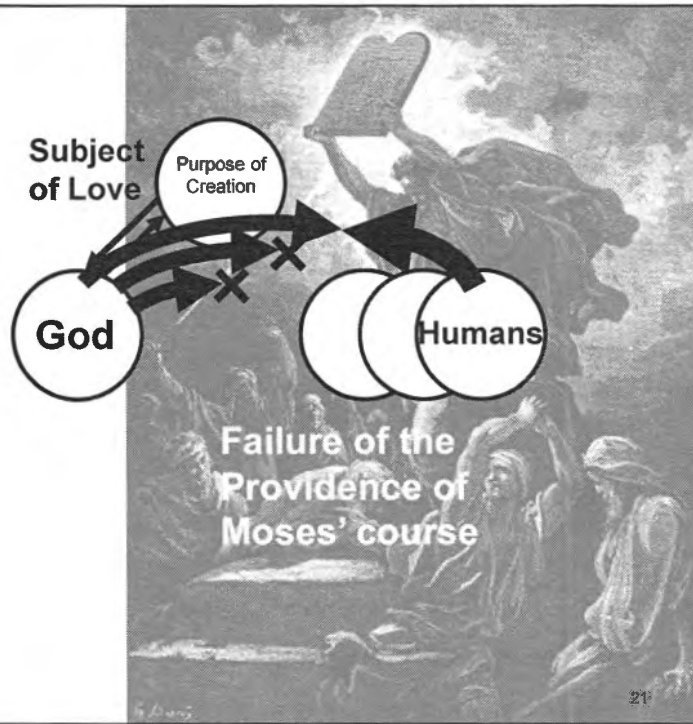

⑭ The Bible says, "...how often I have longed to gather your children together, as a hen gathers her chicks under her wing, but you were not willing." (Matthew 23:37)

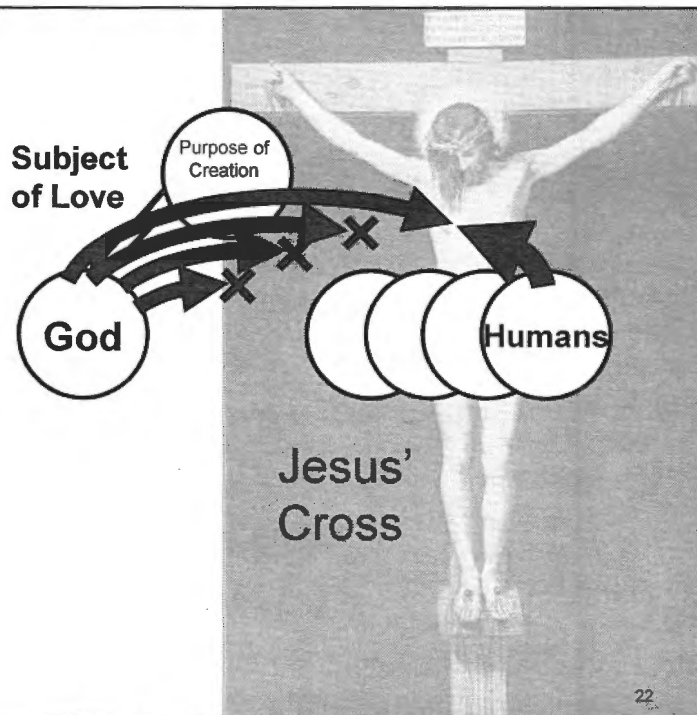

⑮ “You (God) put Yourself in the midst of suffering because of the sins of Your children, Adam and Eve. You have no reason to be suffering in this manner, and yet You put Yourself in misery and searched for, and waited for Your child whom You can depend on for the longest time.” (May 1, 1977)

⑯ “Heavenly Father never experienced the spring... He has stayed in winter, since the human fall.” (1978.4.16)

23

R-4

⑰ “When one of these people—or a prophet or a priest —asks you, ‘What is the burden of the Lord?’ you shall say to them, ‘You are the burden, and I will cast you off, declares the Lord.’” (ESV: Jeremiah 23:33)

24

“For God so loved the world, that He gave His only Son, that whoever believes in him should not perish but have eternal life. For God did not send His son into the world to condemn the world, but in order that the world might be saved through him.” (ESV-John 3:16-17.)

⑱ “God cannot forget the original blissful love He had felt so freely and naturally before the fall of Adam and Eve took place.”  
(February 19, 1971)

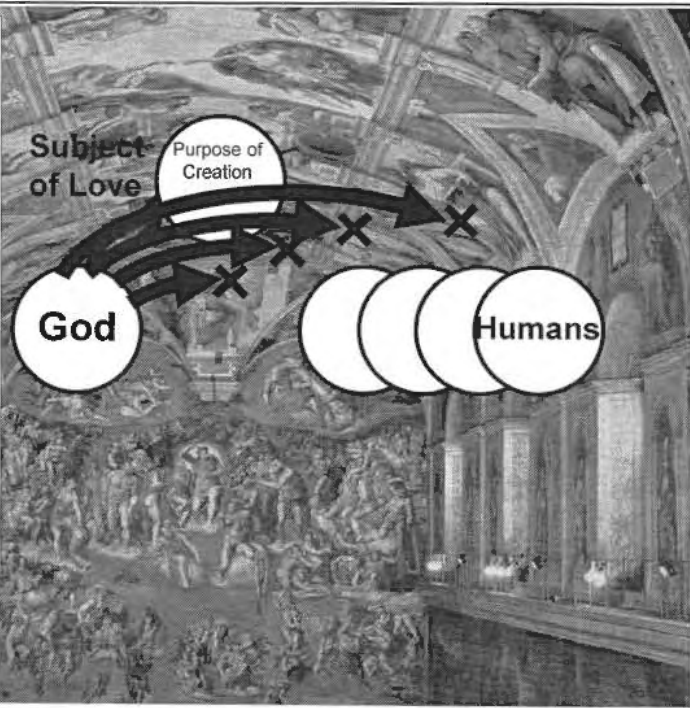

⑱ The Bible says, "But as the days of Noah were, so shall also the coming of the Son of man be." (Matthew 24:37)

R-4

⑳ The Bible says, "He who testifies to these things says, 'Yes, I am coming soon.' Amen. Come, Lord Jesus." (Revelations 22:20)

㉑ The Bible says, "But first he must suffer many things and be rejected by this generation." (Luke 17:25)

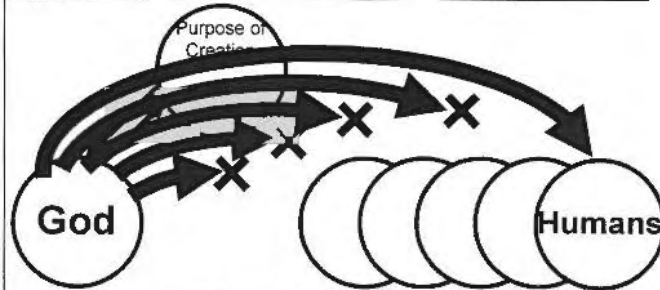

Second  
Advent



㉒ The Bible says, "I tell you, He will see that they get justice, and quickly. However, when the Son of Man comes, will He find faith on the earth?" (Luke 18:8)

27

B. "...the emotional force that the object partner returns to the subject partner is called beauty." (DP. p. 48)

R-4

After experiencing the subject partner's true love and Shimjeong with all Jeongseong, the object partner develops the Shimjeong to love the subject partner with upmost sincerity. This is beauty.

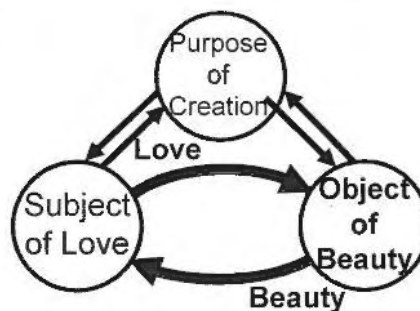

a. The Messiah's Hyojeong as Beauty in Response to God's Love

The Messiah is the first human who correctly received God's parental love and walked the path of Hyojeong to God.

① The Bible says, "My Father is always at His work to this very day, and I, too, am working." (John 5:17)

28

② "I have experienced the most tearful embrace with God, because I completely understand His painful heart of 6,000 years. God is my parent, and no one knows His heart like I do. ... Because of my relationship with God, I can go anywhere for God's will." (June 16, 1967)

③ "The reason why I have been offering my Hyojeong is because I came to know God's Shimjeong." (October 8, 1965)

④ "I dedicated my entire life to receiving God's Shimjeong. No one knows more about God than I do because I know God's Shimjeong. For this reason, I can give love that shines brightly with God's love." (September 11, 1977)

R-4

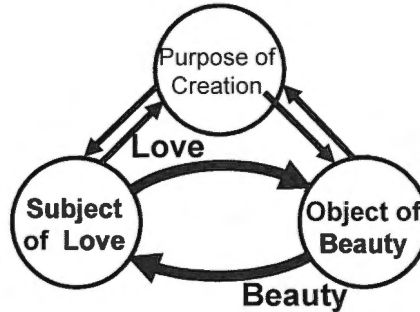

29

⑤ "No one on earth knows the depth of sadness that I shared with God in His embrace. Our Shimjeong was simply immeasurable. My cells tingle with excitement when I think about it. Do you understand my path of filial piety based on such Shimjeong?" (October 13, 1970)

⑥ "I can no longer leave God lonely and isolated as He has been. I must restore the ideal, and this is my mission." (January 1, 1993)

⑦ "I have walked the path of my life with the heart of parental love and filial piety." (June 25, 1967)

R-4

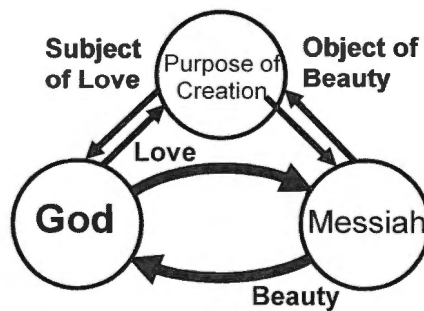

30

⑧ "The path of God's will is just as precarious as carrying God on your back and walking a long distance in deep water that goes up to your neck. If I fall and drown, the path of God's Will will collapse." (Blessed Family and the Ideal Kingdom I, pg. 108)

⑨ "There are numerous abysses stretching around us. The cosmic restoration requires our filling these gaps, and that is what I am worried about day and night." (January 28, 1965)

⑩ "This son of yours has a heavenly mission that he must carry out even if he faces death ten thousand times. I got up and fought again every time I was beaten." (August 16, 1985)

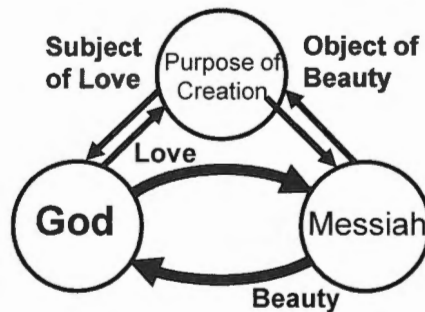

R-4

31

### b. True Mother's Beauty as Hyojeong

① "I sympathize with Mother. She barely slept for two hours last night, so she feels dizzy today. And yet I brought her here. She is a public person."

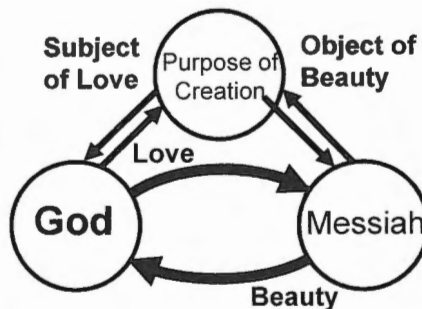

She is not fortunate enough to be able to rest when she suffers from dizziness. She must go on regardless, because she has responsibility and representation for the whole. Yet, she doesn't complain to me. I am very strict when it comes to public missions. Knowing me, Mother follows my path even if she collapses and dies." (October 22, 1978)

32



② "I am Eve, selected finally by Heaven! The 6,000-year providence of suffering must end in my generation! This is the core belief in my life of faith..."

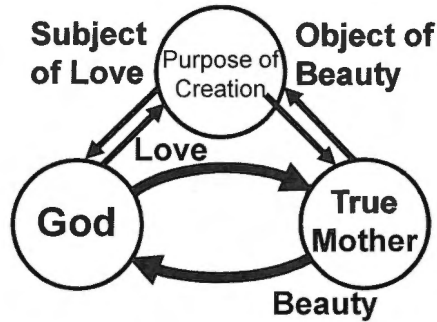

True Mother's Hyojeong

I stood and took on the mission in response to the love of God and Father who guided and protected me. I also responded to the solemn demand of the present age." (True Mother, December 19, 1992)

a. God's Beauty

C. The Divine Principle says, "... beauty is found within love." (p. 48)

What is the meaning of this?

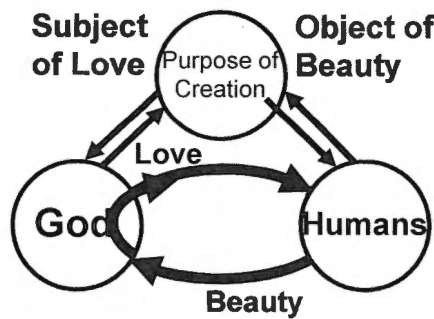

A man who received God's love, before returning beauty through Hyojeong, tries to find out about the heavenly love, or Cheonjeong, that he was given for so long. When God sees such a man, what will he do?

① "What does God do when he sees a man struggle to search for Cheonjeong? When God sees this man get hurt and suffer in the most miserable circumstances, not for himself but for Heavenly Parent and the ideal world, wouldn't God embrace him and cry with tears?" (July 5, 1959)

② "We received true things from God. He invested all His heart and soul to create things and gave them to us. In response, we offer all our soul to lead a life of Hyojeong.

Seeing that, God is pleased with His creation of man and things. He is happy that He selected you." (October 3, 1965)

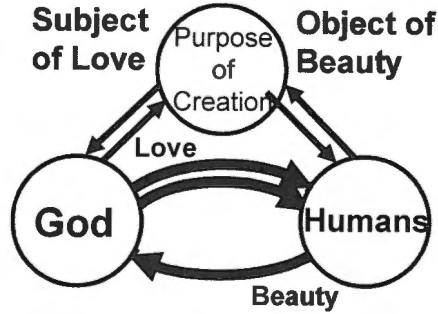

When humans recognize God's love and try to respond with Hyojeong, God gives additional love because of human Jeongseong. This is God's beauty that He gives in response to human love. A desire to respond to human love emerges within God, and is God's beauty. This is the meaning of "beauty found within love."

When humans receive God's additional love that comes in response to human love, they seek to return more beauty to Him.

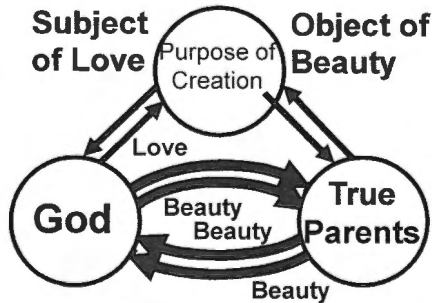

③ "My offerings to God are small, but I realize that God wants me to have thousands of times more results. Knowing such Shimjeong of God, I keep wondering how I can repay Him." (October 13, 1970)

D. "... love is found within beauty." (Divine Principle. pg. 48)

What does it mean?

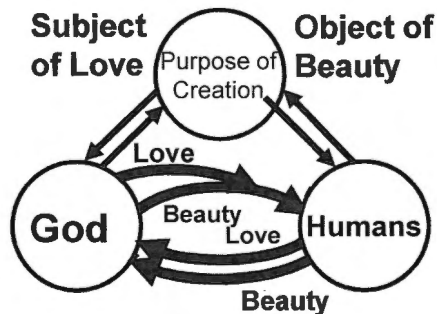

The object partner not only responds in love but comes to initiate love for the subject partner unconditionally. This is the meaning of "love found within beauty."

① "We must accomplish the perfection of the family, clan, nation, world, and cosmos, as well as the liberation of God! We must become the most filial children of God and liberate Him, because He had so many rebellious children. We didn't know about His sorrow till now. God, our Parent, has had sorrowful circumstances. We as filial children do anything and everything to liberate God from the tears of sorrow from thousands of years." (April 12, 1997)

② “It is not easy to figure out how to walk the path of filial piety for God. The problem of indemnity exists. Tragic history continues everywhere till today. In order to indemnify all that, I must become an offering in more miserable circumstances than anyone.” (June 25, 1967)

③ “The Messiah is someone who agonizes, shed tears, and works more than God does. He is destined to go down to hell, but then rises so he can comfort God. God’s tears will turn into tears of joy.” (March 1, 1978)

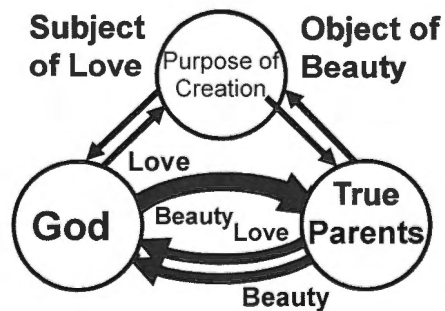

④ “I loved and believed in God more than anyone did, and I accepted God’s every command with utmost sincerity, so I could establish all the necessary indemnity conditions alone.” (February 3, 1965)

⑤ "Who is better, a child who knows his parent is carrying a burden but wants to be released from his own sorrow, or a child who only wishes to make his parent happy?"

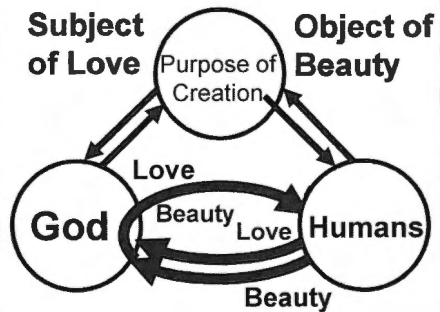

Who doesn't want a child wanting to comfort his parent? Even if we receive no help from Heavenly Father, we want to work for the will of God." (Shintenchi publication, issue 1972.6 , pg. 89)

R-4

41

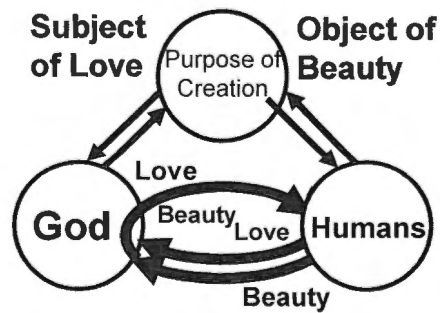

⑥ "When you pray to God, you can ask Him to simply watch you because you don't require His help. God is greatly comforted by such a man or woman." (Shintenchi publication, issue 1972.6 , pg. 89)

⑦ "God's wish is to shed tears of joy and gratitude for His children working for His will, not the tears of sorrow that He has shed before." (March 1, 1978, Malsm, pg. 94)

R-4

42

⑧ “When we think of the fact that You live this way with us, an earnest desire to take Your hand and never let go wells up in our hearts. Our hearts desire to put our arms around your neck and follow you on a mountain path or any other perilous way.

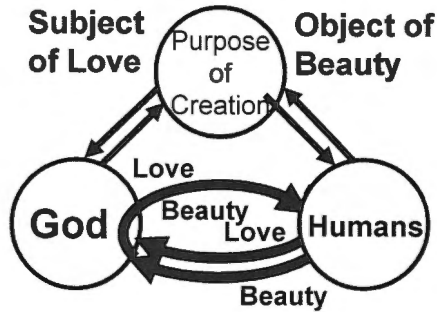

Please enable us to know You, and to know that only when this yearning to carry You on our backs, even when lacking energy, dominates our hearts and overflows in our daily lives will we have fulfilled our duty of filial piety and loyalty..”  
 (Cheon Seong Gyeong June 4, 1970, )

⑨ “When a child goes to jail, he is physically confined, but his parent gets confined in Shimjeong. ... Until the child is released, the parent is never liberated. ... Therefore, we must establish a new tradition of Shimjeong, create a world of Shimjeong, and liberate God.”  
 (April 23, 1972)

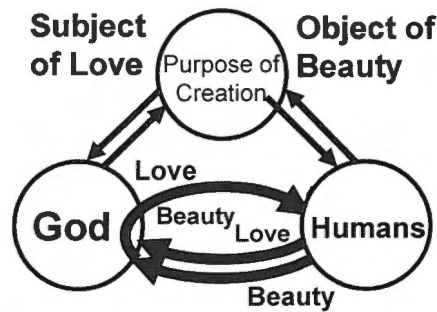

⑩ "Children of filial piety make their parent cry many times. The parent sheds tears of joy when comforted by the children." (August 21, 1971)

⑪ "The world will be restored only after we make God cry tears of joy dozens of times." (June 16, 1967)

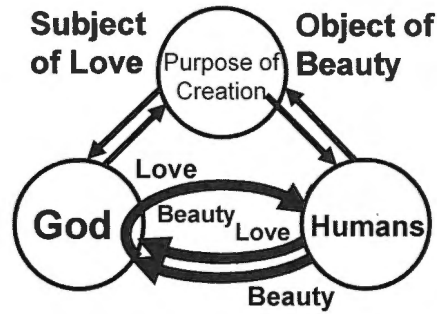

⑫ "A word from true children of filial piety makes God cry. Also, a word from God can make his children cry. Did your word move God and make him cry? Did you and God embrace each other and thank each other?" (August 21, 1971)

### 8. God and True Parents in Cheon Il Guk

① "Yet when I go before God and say, "Here I am, Sun Myung Moon," I would wish to see God shedding tears of joy over the return of His son. God's heart has been filled with unfathomable pain and suffering. Therefore I cannot die until I hear God's own voice say, "Welcome!" as He runs down a stairway of a hundred thousand steps as if He is flying, wraps

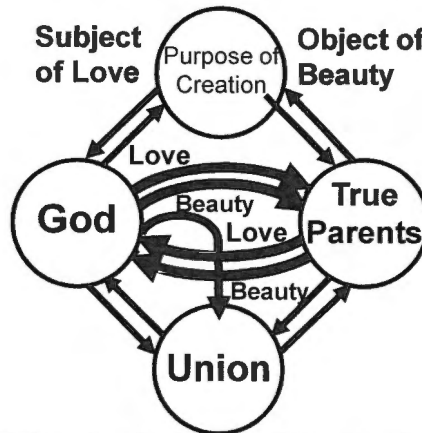

His arms around me, then climbs back up the forever-long stairway to return to His throne, carrying me in His arms and announcing, "My Will has been accomplished! Aju!" Therefore I can only continue fulfilling the Will on the path of the ironclad Principle that True Parents are destined to walk." (January 31, 2003, Cheon Seong Gyeong, B8-C4-S1-13)

## 9. The Eternal Treasure in Cheon Il Guk

R-4

① "The educational goal of the Unification Church is to prepare our members for their admission to the high spirit world." (Blessed Family and the Ideal Kingdom, pg. 318)

② "I have walked the path of parental love and filial piety. You have also walked the path of filial piety by sacrificing yourself and thinking of God's suffering, even when you face the most difficult circumstance. This standard you established is your historical treasure." (June 25, 1967)

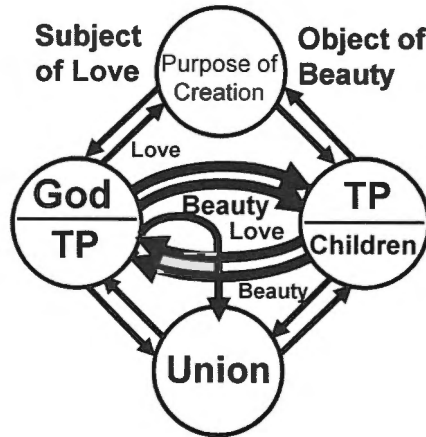

③ "If you make God and me cry for joy, ... God cannot separate from you; He will always be with you." (August 21, 1971)

47

④ "Your eternal treasure depends on how many people you loved during your life on earth. How many people did you love from this standpoint? You will be qualified to stand before God if you developed the heart to love all people, including the rich and the poor of society. If you have nothing to offer and go to God, he will ask why you came. We dedicate our entire life for the moment when we can stand in front of God. That is right. The reason why I have been walking this path of suffering is because I want to have God welcome me with a smile and all people in praise." (July 3, 1970)

48



⑤ "Today, having concluded that 40-day period, we are at the starting point of a new providence. True Father is making a new start in the spirit world. Hence, in order to return glory to heaven and bring settlement to Cheon Il Guk on earth, we also will have to make a life-and-death determination and totally invest ourselves. We must walk in step with True Father.." (True Mother, October 25, 2012, Cham Bumo Gyeong)



## 10. The Completion of the Three Object Purpose

① "As a result of origin-division-union action, our positions are formed: the origin at the center, the subject partner and the object partner, and their union. Any one of the four positions may assume the position of subject partner and engage the other three as the object partners, forming a communion of three object partners. When each of the four then acts as the subject partner and enters into give and take with the other three revolving around it, they fulfill the three object purpose." (Divine Principle, pg. 37)

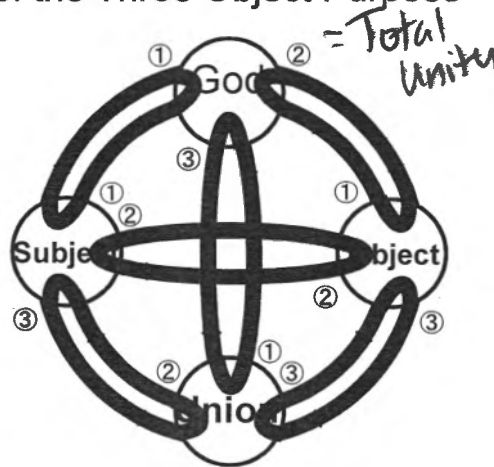

② "The three object purpose is part of the principle that supports the cosmos. We must fulfill the top-bottom, parent-child, husband-wife, children's, and siblings' relationships with God in the center." (December 1, 1998)

### 11. The Completion of the Four Position Foundation through the Four Realms of Heart

① "When through origin-division-union action, the origin, the subject partner and the object partner projected from the origin, and their union all fulfill the three object purpose, the four position foundation is established. ... Therefore, the four position foundation is God's eternal purpose of creation." (Divine Principle, pg. 38)

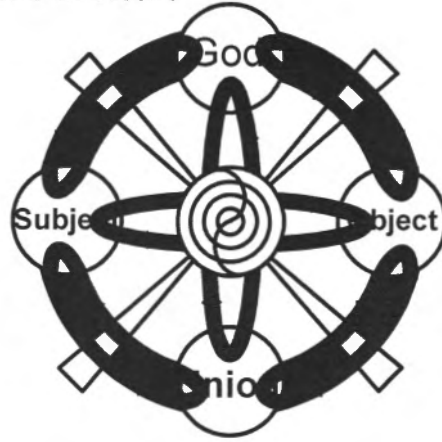

② "God dwells in a family that forms the realm of God's love through the three object purpose. Such a family owns God, manifests God's eternal love, ideal, and creativity, and inherits God's ownership." (Blessed Family and the Ideal Kingdom I)

### A. Further Understanding of Origin-Division-Union Action and the Four Position Foundation

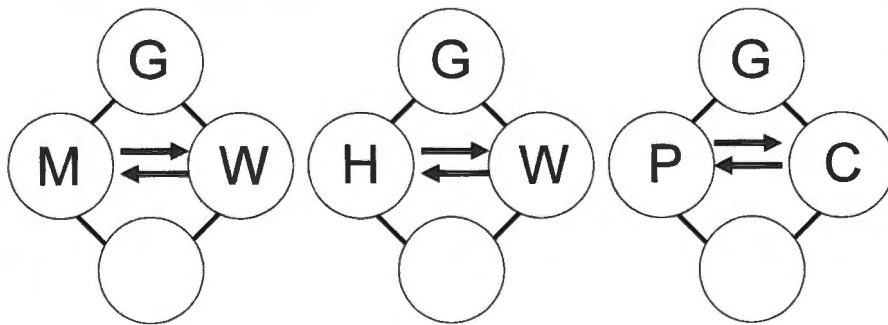

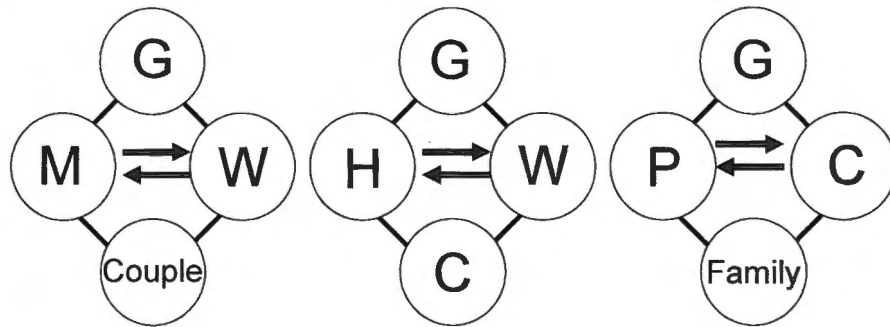

**a. Identity-Maintaining Origin-Division-Union Action**

The origin-division-union action that unites and harmonizes entities is called sustaining origin-division-union action.

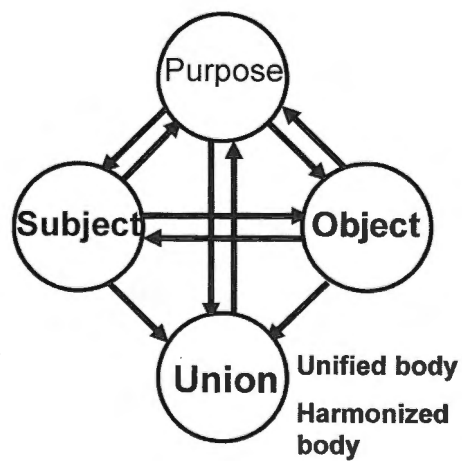

In God, original internal nature and original external form are in unity. In creation, the protons and electrons comprise an atom; mind and body comprise a human; a husband and a wife unite and harmonize to become a couple; and parents and children unite and form a family.

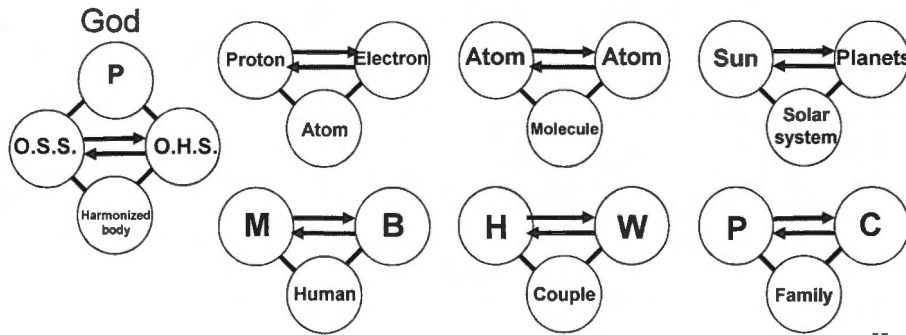

**b. Developmental Origin-Division-Union Action**

Expansive origin-division-union action leads to the creation of a new entity. God's plans in the form of original internal nature and corresponding original external form interact to bring about creation, and in creation, stamen and pistil generate seeds of plants, male and female produce offspring, and husband and wife unite and give birth to children.

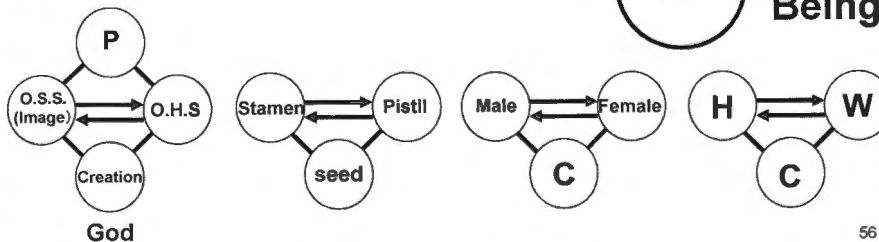
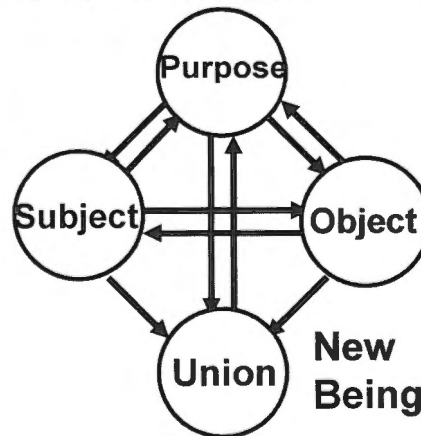

### c. Transfer from Identity-Maintaining Origin-Division-Union Action to Developmental Origin-Division-Union Action

R-4

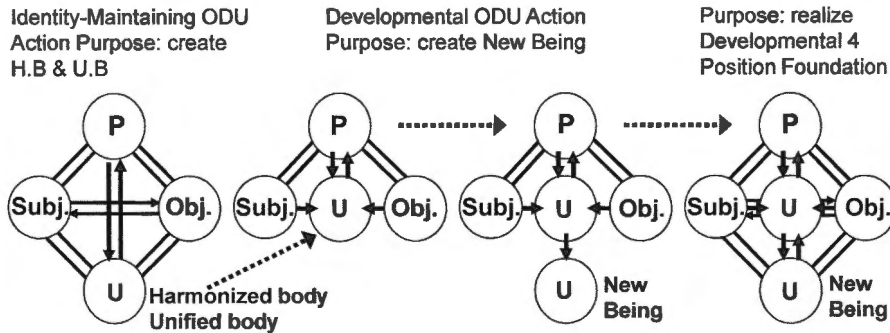

When a subject partner and an object partner engage in give and take action through sustaining origin-division-union action, they unite in harmony. When they interact through expansive origin-division-union action, they create a new entity.

57

### d. Completion of the Four Great Realms of Heart and Four Position Foundation

R-4

I. Attainment of the first Realm of Heart (Shimjeong of children)

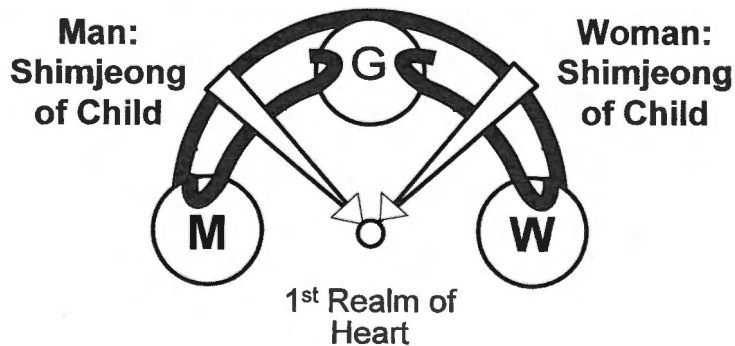

God's children—boys and girls—unite with God through love and beauty; they attain the Shimjeong of children.

58

**II. Attainment of the second Realm of Heart  
(Shimjeong of brothers and sisters)**

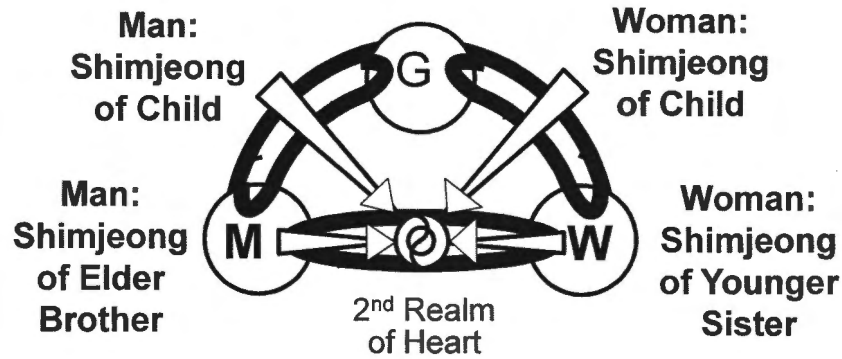

On that foundation, siblings unite through brotherly and sisterly love and beauty; they attain the Shimjeong of siblings.

**III. Attainment of the third Realm of Heart  
(conjugal Shimjeong)**

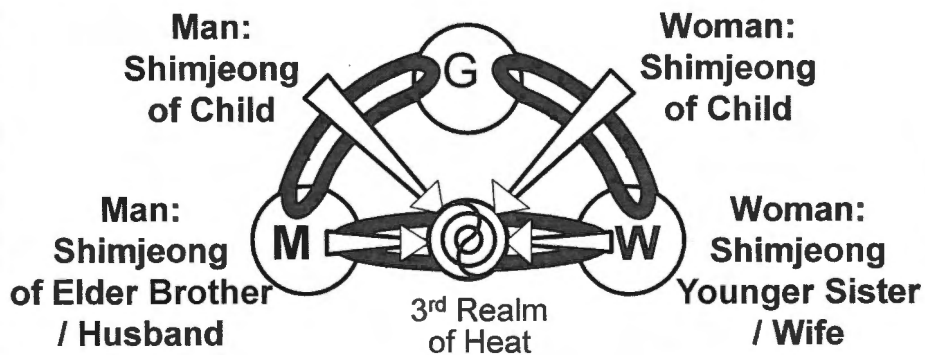

On that foundation, a man and a woman unite in marriage and exchange love and beauty; they attain the Shimjeong of husband and wife.

**IV. Attainment of the fourth Realm of Heart  
(Shimjeong of parents)**

R-4

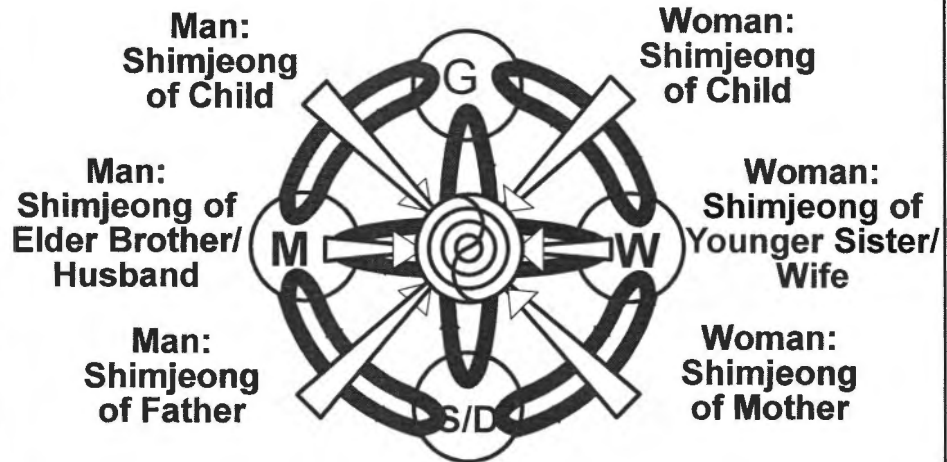

Further, they raise children and attain the Shimjeong of parents. The Four Great Shimjeong are achieved in the process of completing the family-level four position foundation. 61

**Pledge Service on True Parents' Birthday  
(2018.2.21, Cheon Jeong Gung)**





V. Completion of the Four Great Realms of Heart <sup>R-4</sup>  
by Children

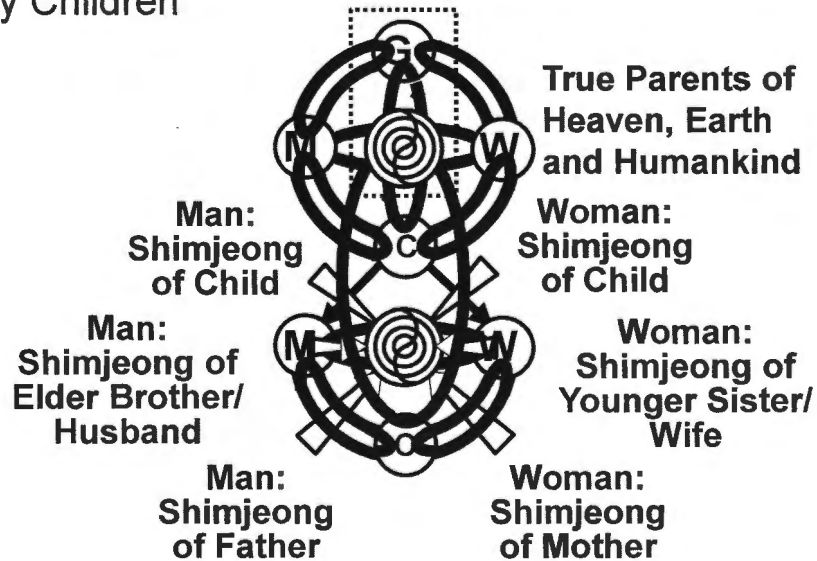



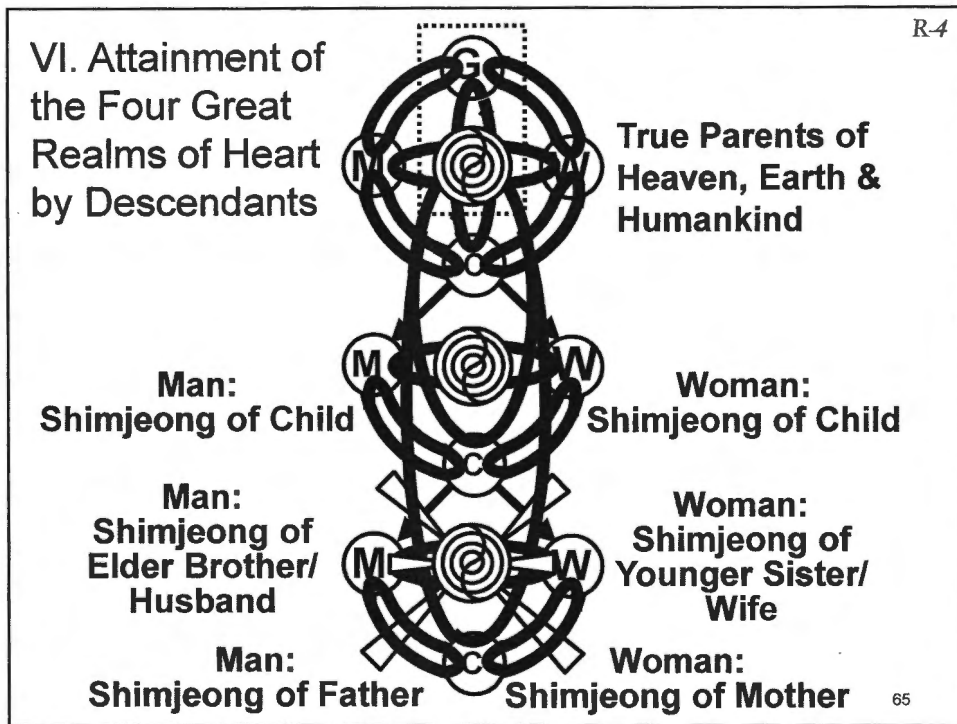

① “The vertical and front-back true love relations between God and humans constitute the foundation for ideal love relations among humans, which can be achieved only through the Four Realms of Heart in ideal families. The culture of heart blossoms in the unified realm of ideal families, who attain the Four Realms of Heart, where everyone enjoys peace, happiness, and freedom.” (Seoul, May 1, 1994)

② “A husband and wife may exist for today, but not for tomorrow, if they have no children. They can disappear tomorrow. A husband and wife must have someone who comes under them. ... Parents complete their responsibility only when their children get married. Married sons and daughters come below the parents who are on the top. God’s ideal requires this vertical relationship. The horizontal relationship of a husband and wife must be linked to their vertical relationship with their children. When multiple children, or brothers and sisters, are added, the entire web of relations form a perfect sphere. ... What is it? This is the Four Position Foundation that we study in the Unification Church. Therefore, the perfection of God’s ideal of creation is equivalent to the attainment of Four Position Foundations.” (Blessed Family and the Ideal Kingdom I)

③ “I can establish certain heavenly traditions in my lifetime, but it is challenging to restore the whole world completely in this generation. This is the reason why we need to link the second and third generations for our remaining historical tasks.” (East Garden, August 16, 1985)

④ “We cannot allow expressions such as ‘American ways are better,’ or ‘My way is good.’ You can reach Heaven only through the way established by True Parents, and not by the traditional approaches in Korea or America.” (East Garden, August 16, 1986)

⑤ “You should have the mindset that you are following the path that God and Father walked. Only that, and nothing else, leads you to the realm of Shimjeong.” (December 29, 1991)

## VII. God's Growth and Perfection

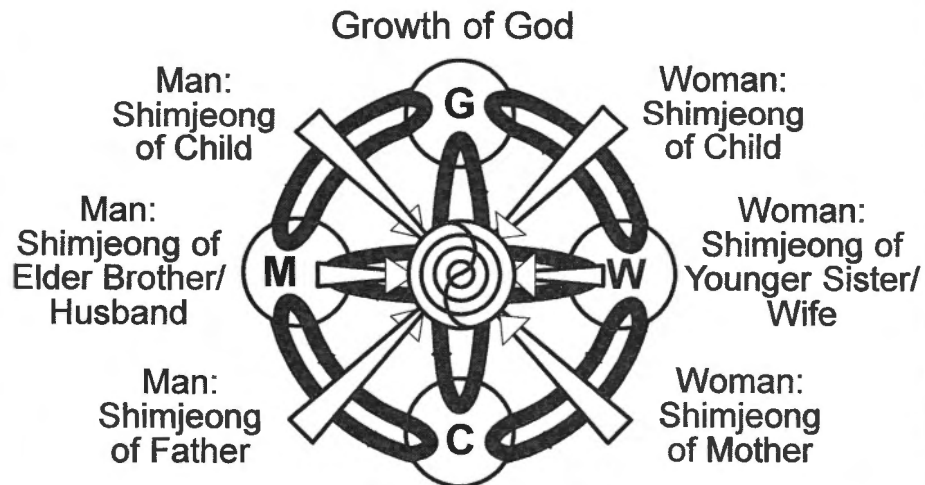

As humans attain victory and grow, the invisible God extends his visible form and grows.

① “When Adam and Eve perfect themselves with true love, God attains his goal of substantiating himself in visible forms. ... Adam and Eve’s becoming True Parents through raising children of goodness actually means that God establishes himself as the eternal parent in substance.”  
(September 10, 1996, The Divine Principle View of the Providence of Restoration)

② “I spent 40 difficult years as True Parent so we can welcome God on earth. When we do, God and humans become one.” (February 10, 1992)

### VIII. Heavenly Parent and True Parents of Heaven, Earth and Humankind <sup>R-4</sup>

True Parents became True Parents of Heaven, Earth and Humankind by their total unity with God, the invisible parent in heaven, and the completion of all the responsibility necessary as human representatives. From now, our members must inherit True Parents’ victory for themselves and for all humankind in order to build our substantial Cheon Il Guk.

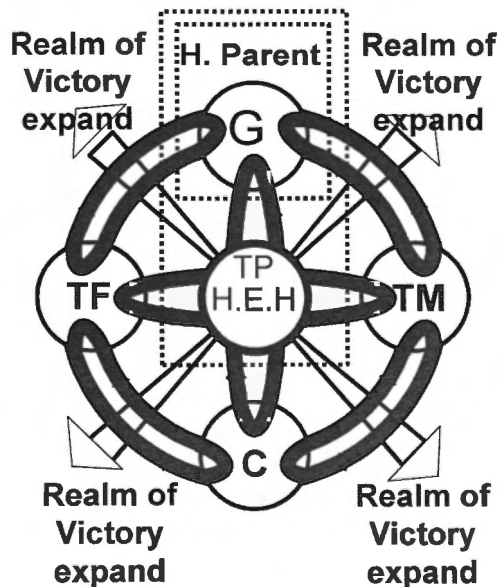

## B. The Unification Flag

R-4

① “The flag symbolizes heaven and earth. ... The entire universe is created by the relationship of give and take. The center of the flag represents the center of the universe, or the sun, if speaking of the solar system, or God himself, if speaking of the entire cosmos.

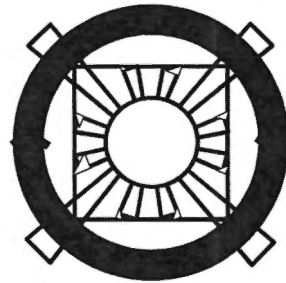

Everything, including our ideal heart, or Shimjeong, is connected to this center. The surroundings represent four directions. One being in the center naturally determines four directions, and that further leads to twelve. The flag has twelve radiuses, just like twelve months in a year, which rotate in a give and take action.... The overall shape looks like a helm to sail a ship.

73

We are driving the universe, so this symbol includes all the Principle of Creation and our ideals. ... There is more to the meaning of the symbol. ... Those of you who embrace the flag in heart and live in God's Shimjeong can drive away all evil trials and betrayals of Satan. ... The flag also symbolized me. Those who come under this flag are one family. ... We have no concept of races or cultures that oppose one another. ... Let this flag lead us to keep advancing with courage until the very end. I pray for every victory in your hand.” (Tokyo, January 29, 1965)

74

R-4

### C. The Diagram Father Drew at His Speech on April 7, 1985

図-6



図-5



75

R-4

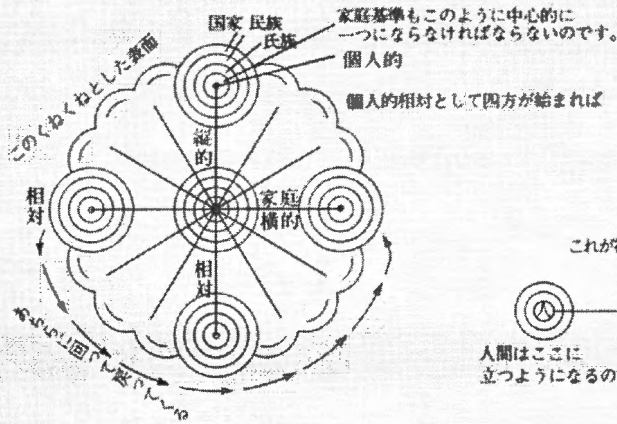
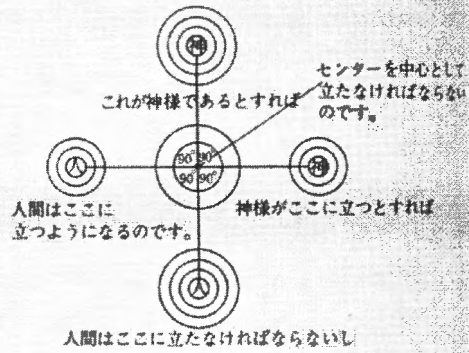
### C. The Diagram Father Drew at His Speech on April 7, 1985

図-6



図-5



76

① "The holiest place of God is where love comes together. The place where love comes together on earth is where a man and a woman unite. This is the holiest fountain for the royal lineage of God's kingdom. ... You must know the astounding fact that, after the fall, this most precious place became the crux of the lineage of Satan.

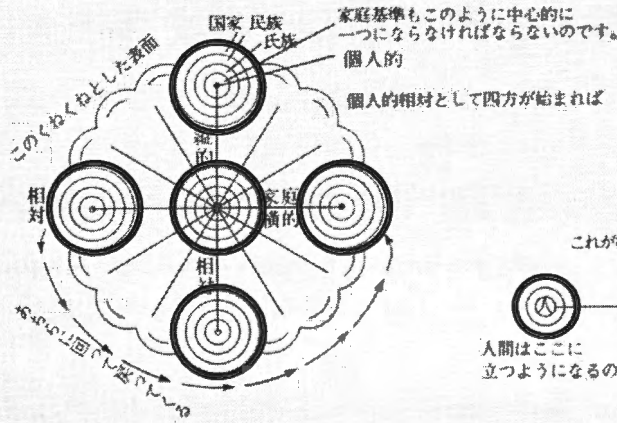
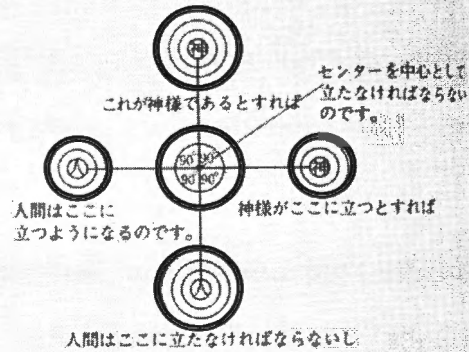
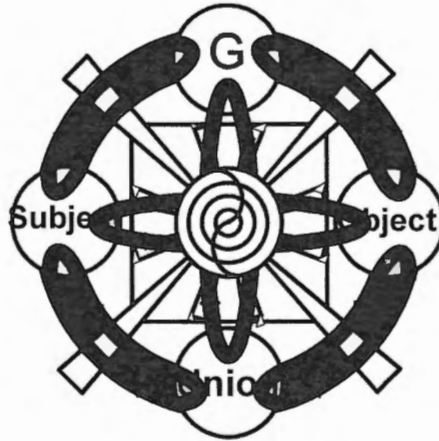

Rev. Moon has worked for 40 years to reverse what happened and create God-dwelling families made up of men and women who keep the holiest place in God's kingdom. For his dream, to build God's families, nation, and world, Rev. Moon received much persecution.

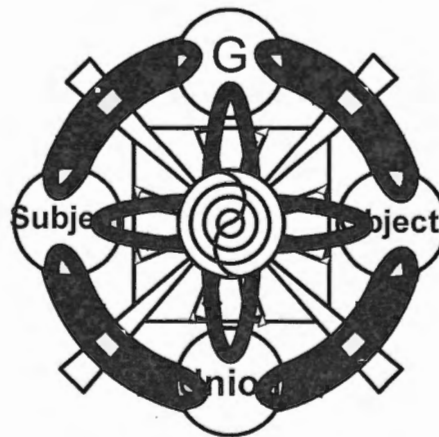

I bowed my head and sighed in despair like a sinner on rainy nights, and walked the path for all kinds of positions, such as a widower, husband, son, and parent. God said not to worry, as I was his chosen one and I needed to persevere only for several years. Yet, he had me walk further and further, letting me consume my youth and the best years of my life.

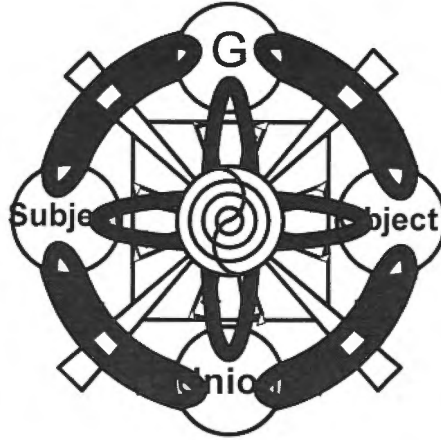

Now, I am sixty, and over the hill. But only Rev. Moon was able to build the world as it is today. Here I am, after working like a crazy man and crisscrossing so many places in search of the lost garden of love." (April 7, 1985)

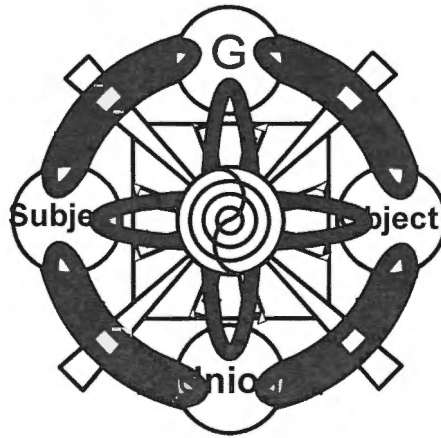



## 12. True Parents and the Four Position Foundation

R-4

① "The Unification Principle is also the record of my life. It is my life experience. This Unification Principle is in me, and I am in the Unification Principle. and me. ... Therefore, the only way for people to truly understand me and my actions is through the Unification Principle. Only by learning the Unification Principle and studying it can you understand me. (February 3, 1977, Cham Bumo Gyeong 5-1-4-10)

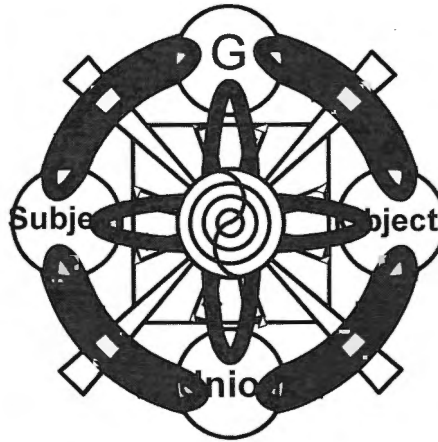

81

② "Simply speaking, the Principle of Creation is a philosophy of the Four Position Foundation. ... You naturally become joyful when you are completing a Four Position Foundation. ... Unless you form your Four Position Foundation, which is your substantial foundation, with your object partner, you cannot enter God's kingdom." (Tokyo, June 18, 1967)

③ "Dearest Father, we have learned through the Divine Principle that the foundation you have searched is the restoration of the Four Position Foundation." (February 1, 1971)

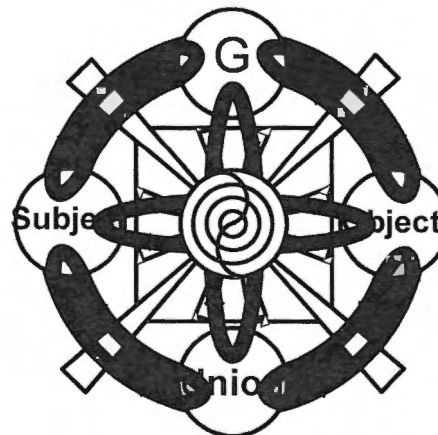

④ "What Rev. Moon teaches is about the currents of Shimjeong. I speak of the current of Shimjeong that can connect with all nations and the whole universe through God's throne and God's Shimjeong" (The Earthly Life and the Spirit World")

82

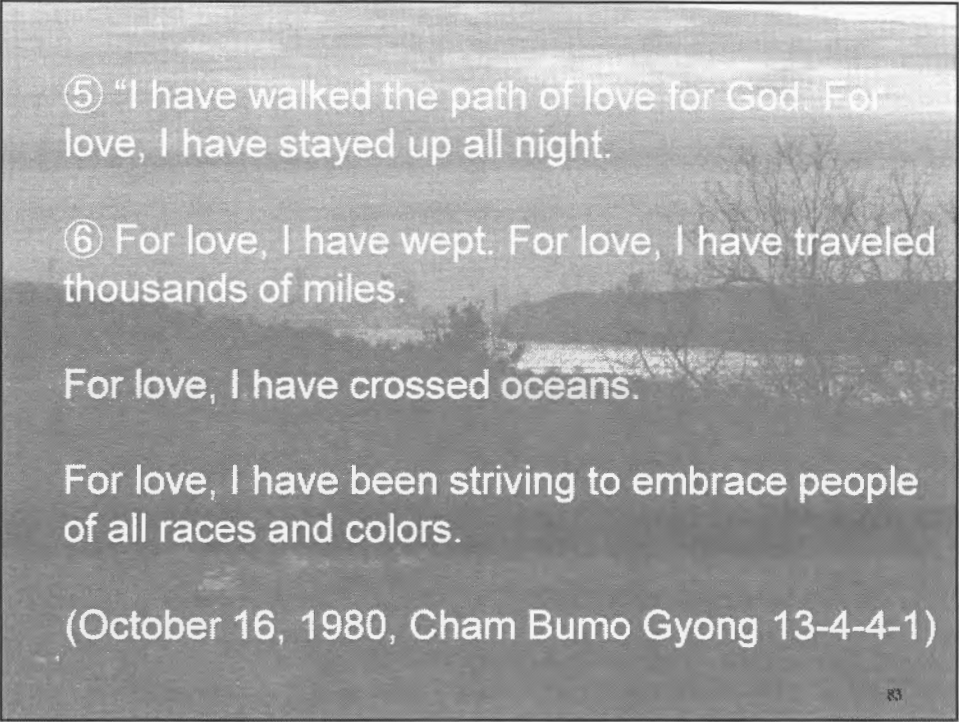

⑤ "I have walked the path of love for God. For love, I have stayed up all night.

⑥ For love, I have wept. For love, I have traveled thousands of miles.

For love, I have crossed oceans.

For love, I have been striving to embrace people of all races and colors.

(October 16, 1980, Cham Bumo Gyong 13-4-4-1)

83

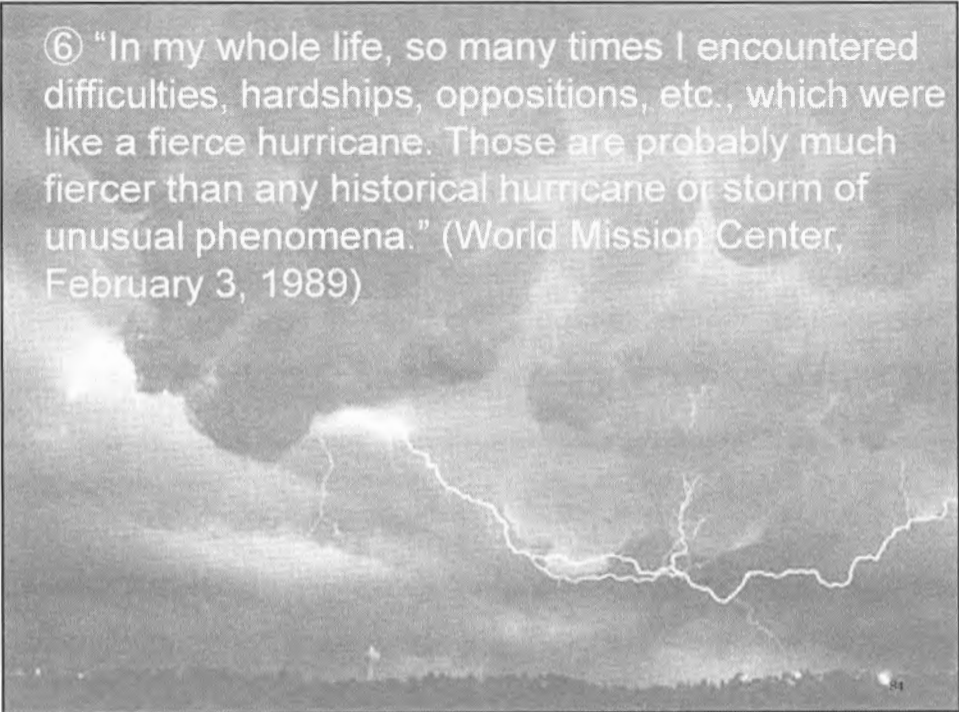

⑥ "In my whole life, so many times I encountered difficulties, hardships, oppositions, etc., which were like a fierce hurricane. Those are probably much fiercer than any historical hurricane or storm of unusual phenomena." (World Mission Center, February 3, 1989)

84

R-4



⑦ "One time I thought how a man could become so weak. From this viewpoint, I am same as you are. Both are weak humans." (Belvedere, May 1, 1977)

85

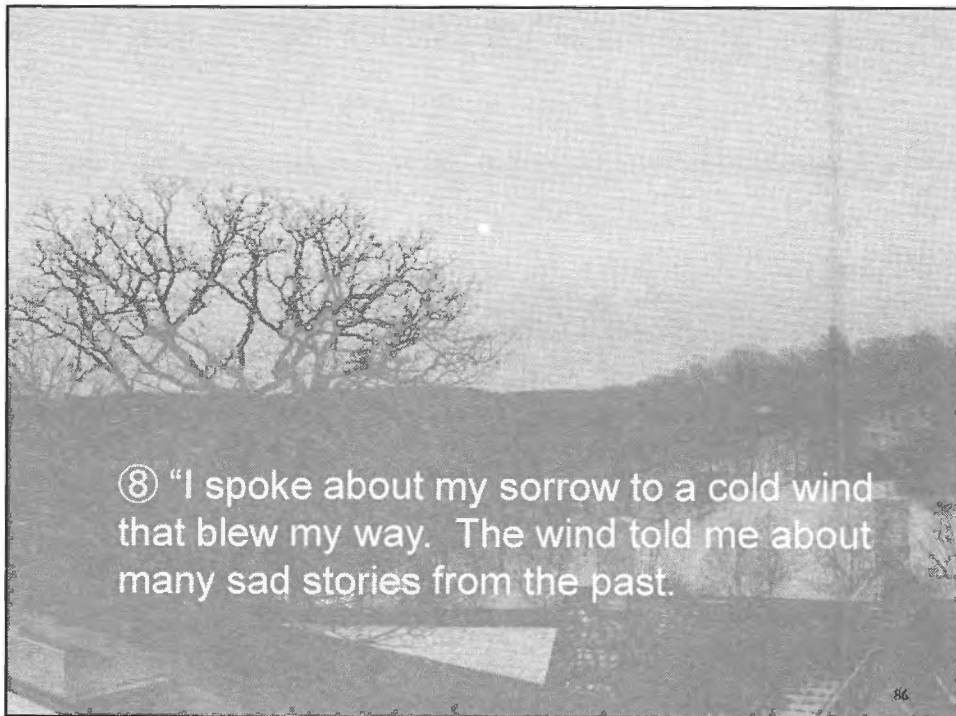

⑧ "I spoke about my sorrow to a cold wind that blew my way. The wind told me about many sad stories from the past.

86

My complicated circumstances are inscribed in the water, which flows like the waves. When I was sad and lonely, I used to grab the sand at the bottom of a river and mumble to myself; I spoke to birds as they flew away.

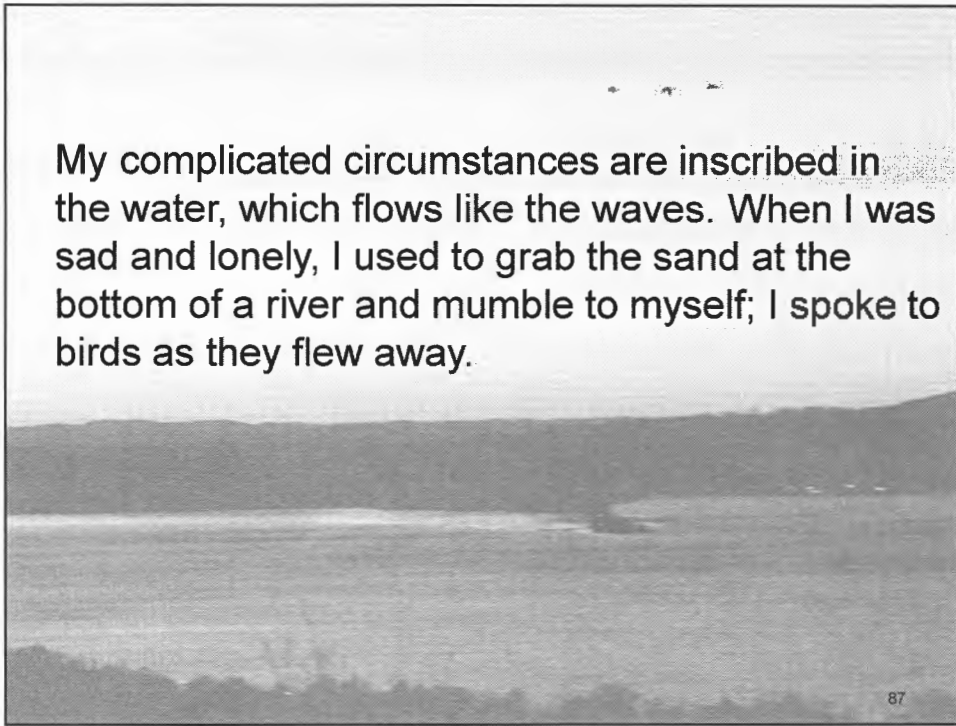

I used to shed tears looking up at bright stars at night." (East Garden, August 16, 1985)

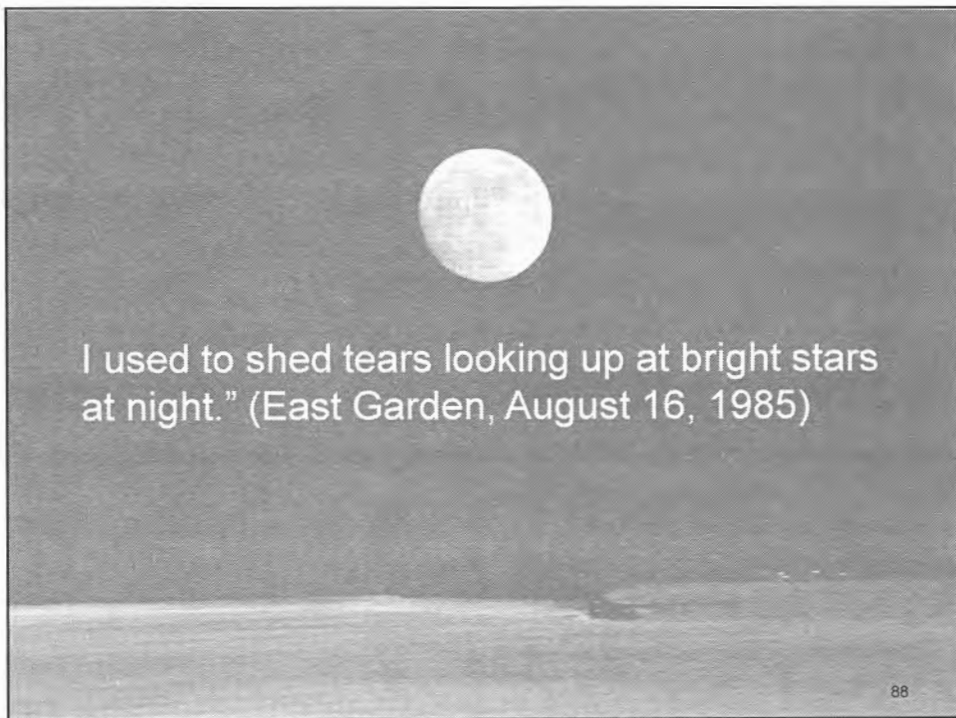

⑨ “My standard goes beyond the level of poverty or hardship. I received all sorts of humiliation that can be thought of. However my heart to love God never changed. I have never lived in comfort. At East Garden as well. Teacher used the place, as a place to shed tears like other places.



East Garden  
Main House  
2<sup>nd</sup> floor

89

... I had continued to shed tears for the sake of God all through my life. God knows this as well. God knows what kind of life Rev. Moon lived... God will never forget the things I had done for God throughout my life.” (September 5, 1982)

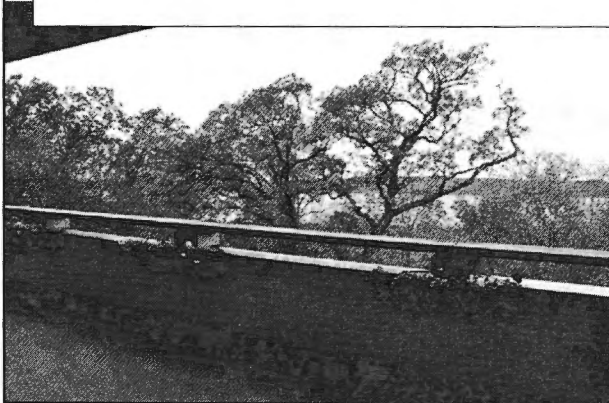

East Garden  
Main House  
2<sup>nd</sup> floor

90

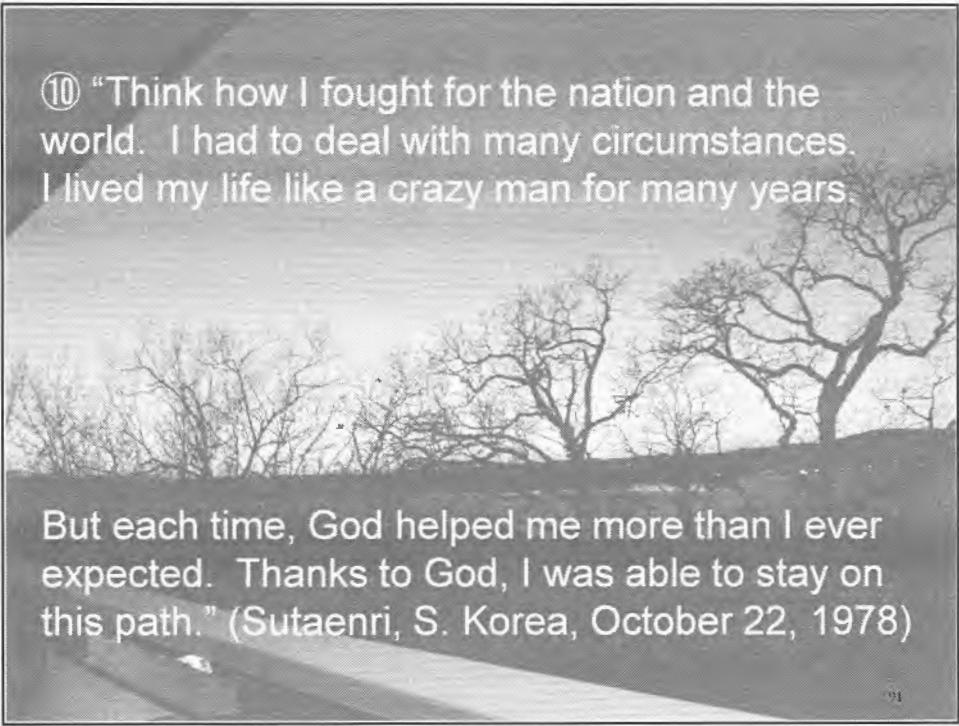

⑩ "Think how I fought for the nation and the world. I had to deal with many circumstances. I lived my life like a crazy man for many years

But each time, God helped me more than I ever expected. Thanks to God, I was able to stay on this path." (Sutaenri, S. Korea, October 22, 1978)

91

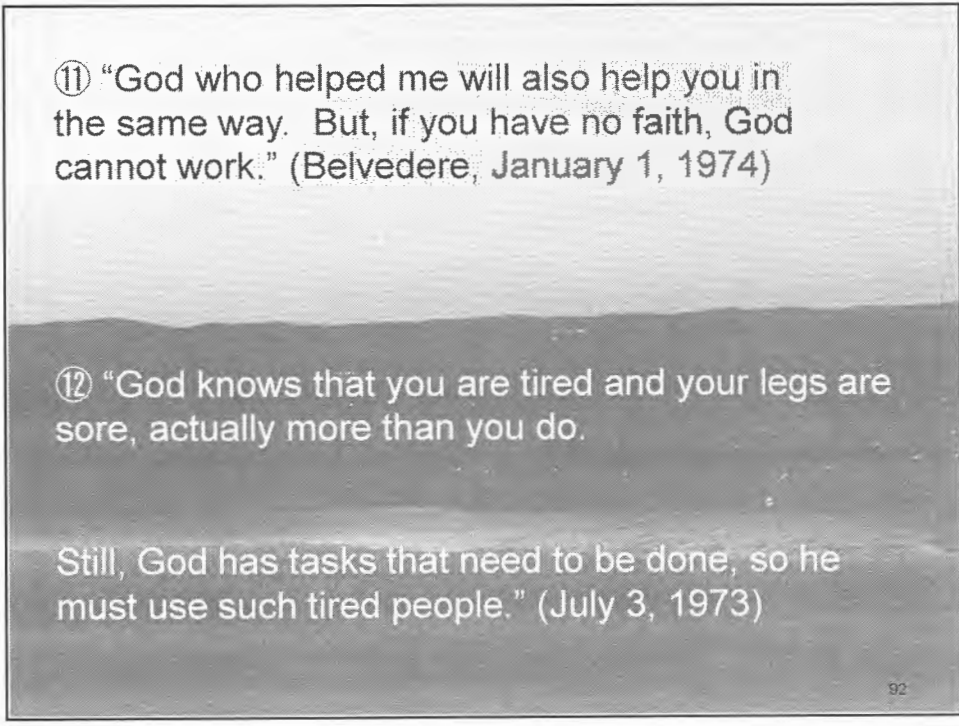

⑪ "God who helped me will also help you in the same way. But, if you have no faith, God cannot work." (Belvedere, January 1, 1974)

⑫ "God knows that you are tired and your legs are sore, actually more than you do.

Still, God has tasks that need to be done, so he must use such tired people." (July 3, 1973)

92

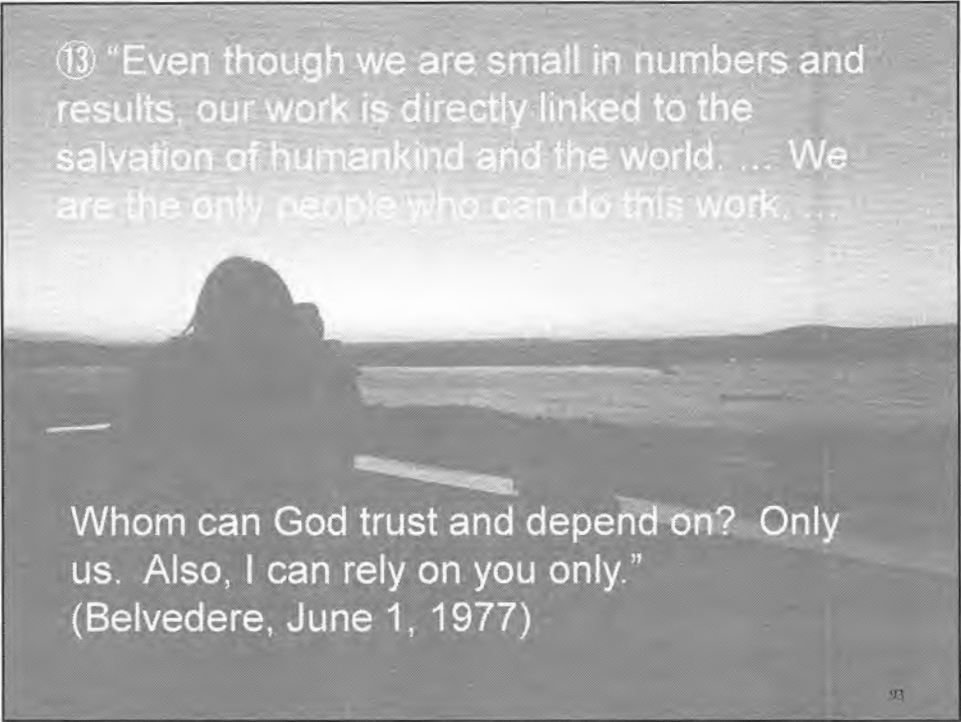

⑬ “Even though we are small in numbers and results, our work is directly linked to the salvation of humankind and the world. ... We are the only people who can do this work. ...”

Whom can God trust and depend on? Only us. Also, I can rely on you only.”  
(Belvedere, June 1, 1977)

93

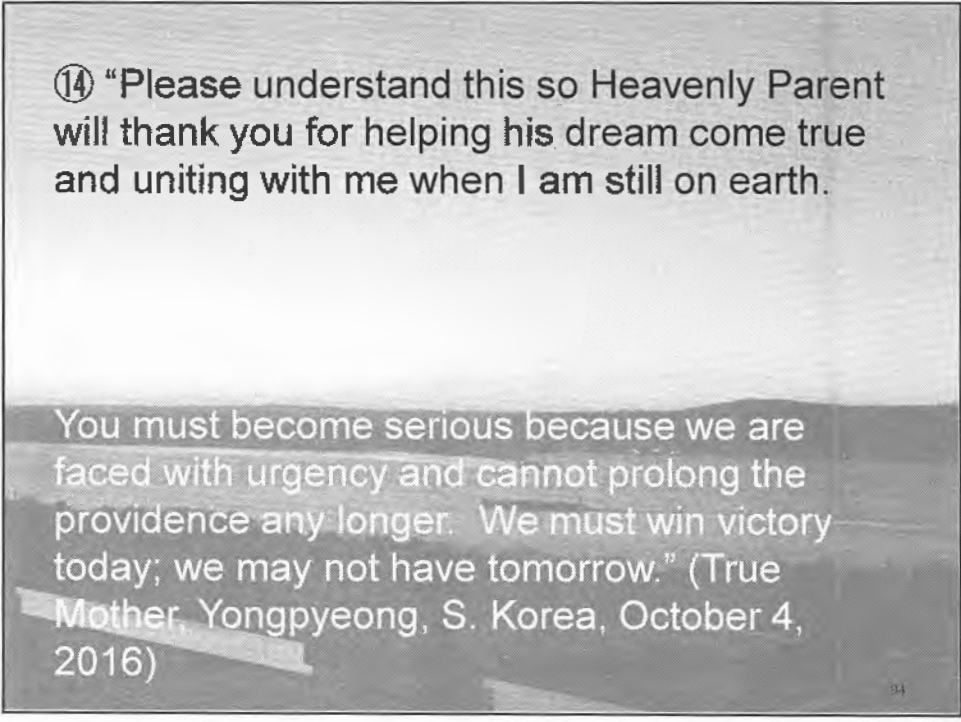

⑭ “Please understand this so Heavenly Parent will thank you for helping his dream come true and uniting with me when I am still on earth.

You must become serious because we are faced with urgency and cannot prolong the providence any longer. We must win victory today; we may not have tomorrow.” (True Mother, Yongpyeong, S. Korea, October 4, 2016)

94

⑮ “You must understand that you are the center that unites the culture of heaven and earth, the focal point of love, and transmitter of God’s love. You also hold limitless energy to spread the thought that brings spring to this country. ... Our heart of parental love from God will generate new creative energy, and the world will come to revolve around us.” (Belvedere, September 11, 1977)

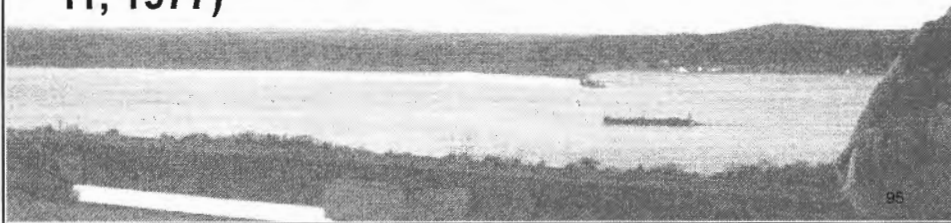

⑯ “I am fighting the final internal battle right now. After going through your external battle, you must win your internal battle like me. In God’s providential history,



you are destined to enter Canaan, the land of milk and honey for all people, with a flying flag of victory and resounding cries of joy.” (World Mission Center, April 7, 1985)

2018.1.1 New Dawn

96



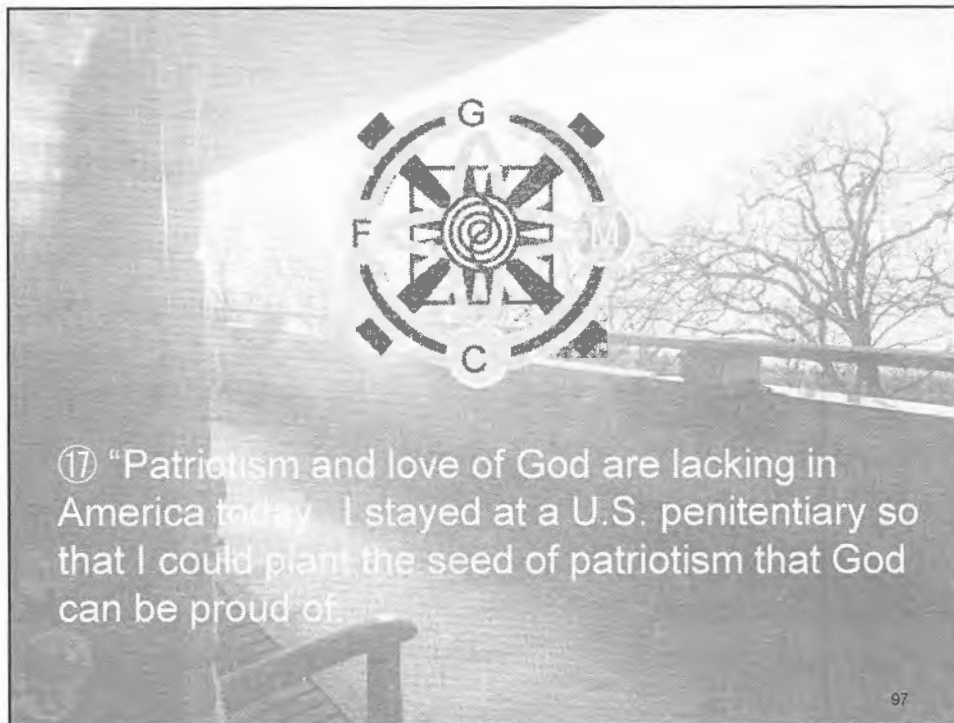

⑰ "Patriotism and love of God are lacking in America today. I stayed at a U.S. penitentiary so that I could plant the seed of patriotism that God can be proud of."

97

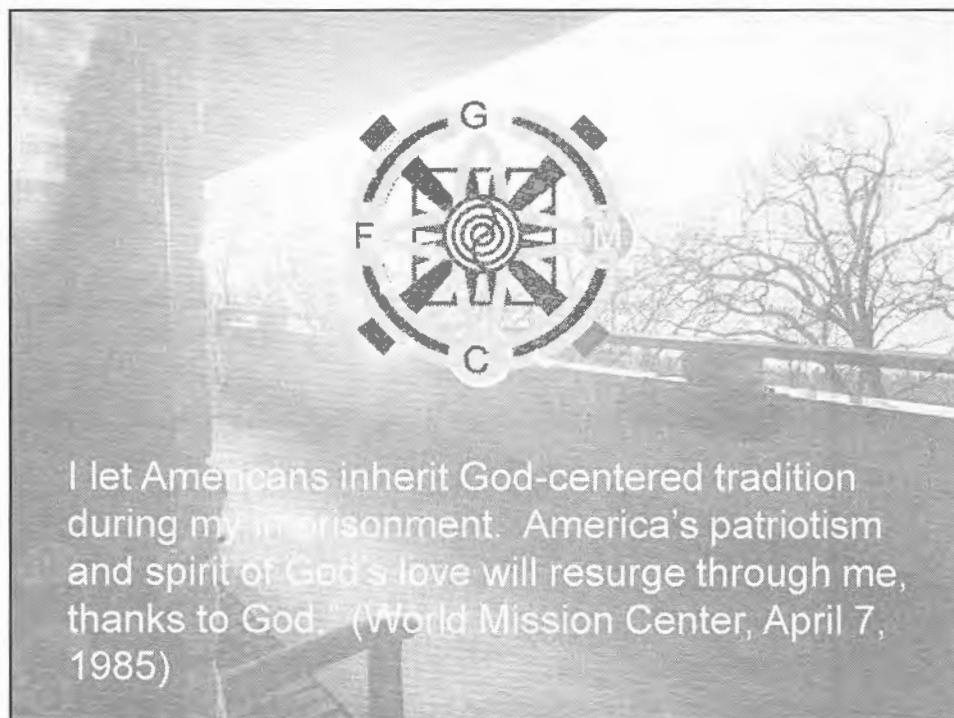

"I let Americans inherit God-centered tradition during my imprisonment. America's patriotism and spirit of God's love will resurge through me, thanks to God." (World Mission Center, April 7, 1985)

Heavenly Korea

Heavenly Japan

Heavenly America

⑱ “We have to prepare a country for God. Which country should we choose? Should we choose a country from Africa, if it is easy? Or America. I chose America, because there are so many Christians who love God.” (1974.1.1)



What season is it?

R-4



98

How old is  
Santa Claus?

R-4

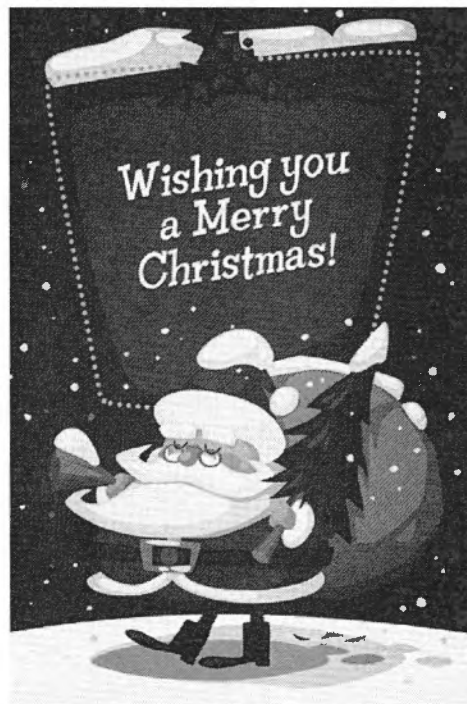

99

What is his body shape?



100

How many houses does he visit?

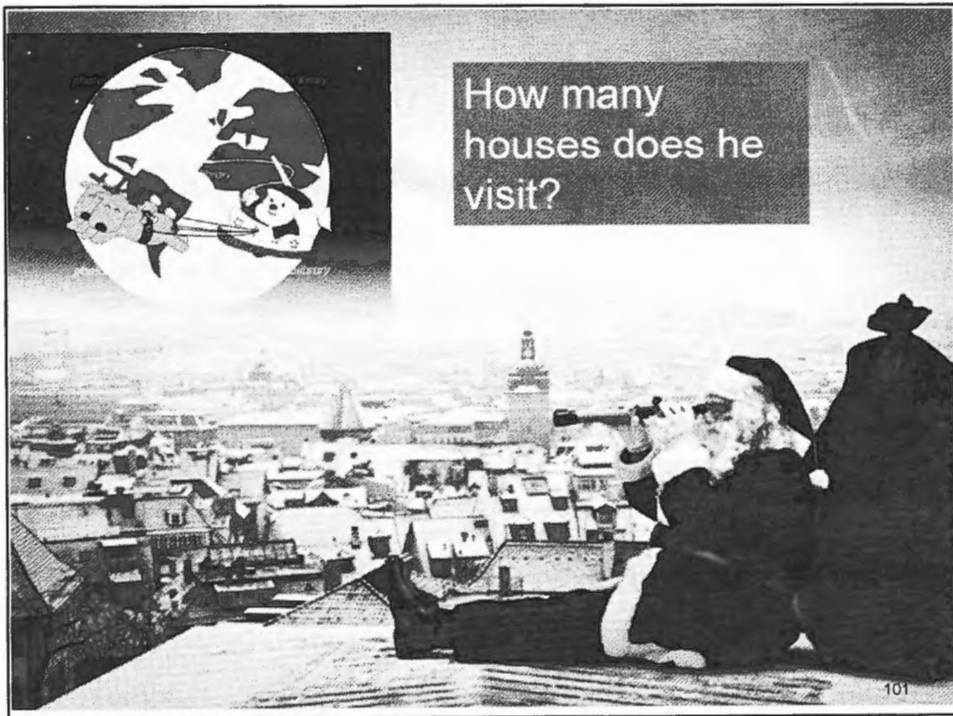

101

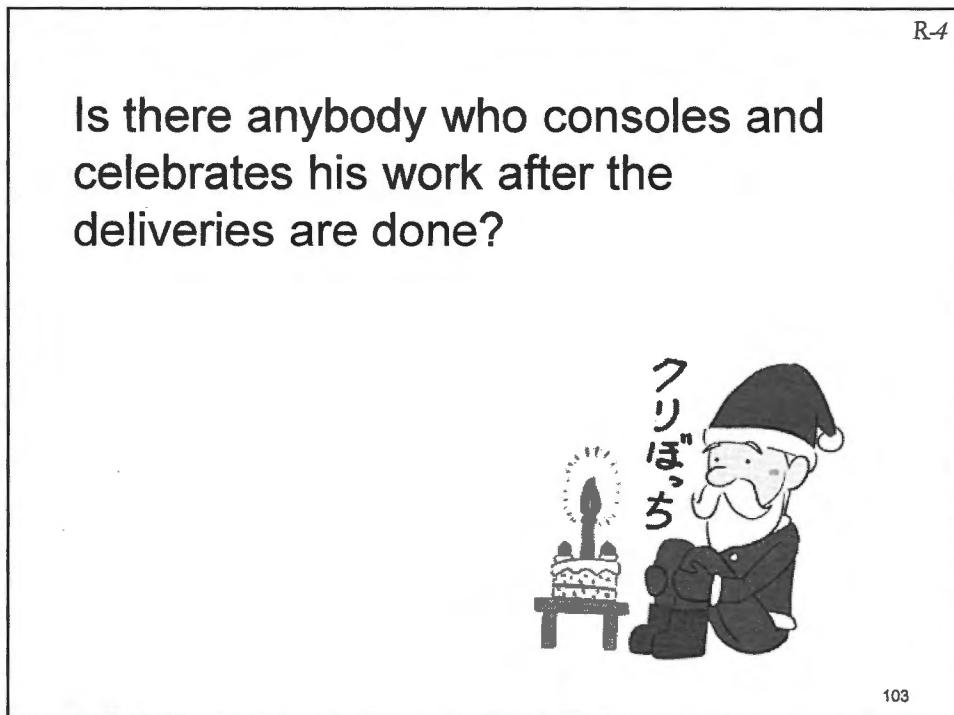
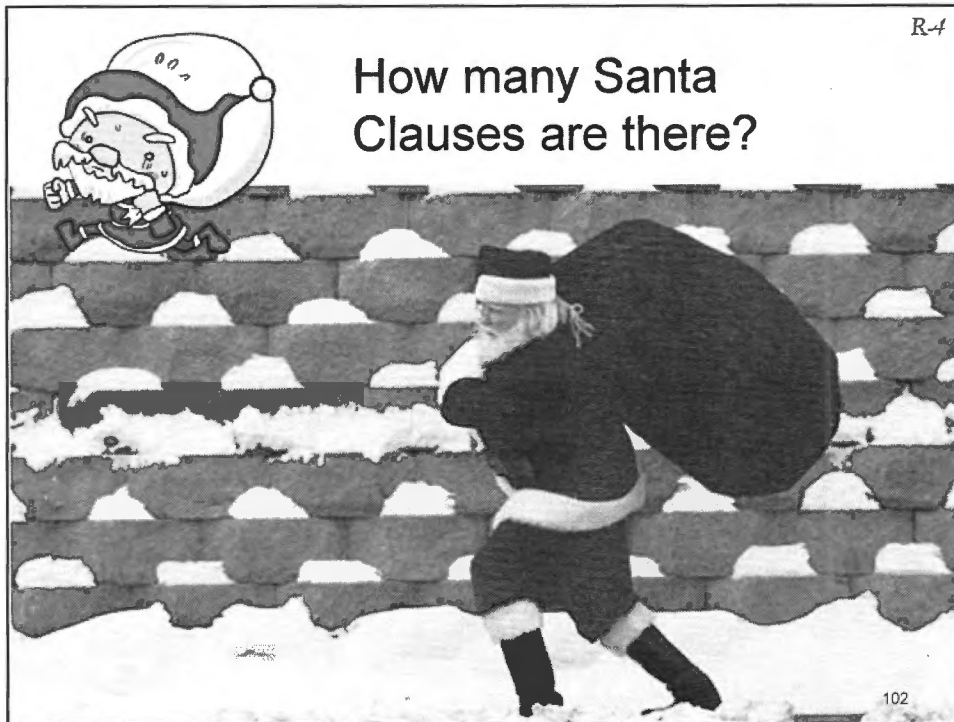

Is there a female  
Santa Claus?



R-4

104



R-4

True Mother is advancing the providence of  
salvation for the world and cosmos, consulting with  
True Father in the spirit world.

105

Inauguration of IAPP (International Association of Parliamentarians for Peace)

R-4



U.S. Senate: The Kennedy Caucus Room, Washington, D.C. (Nov. 30, 2016)

106

General Assembly of IAPP (2017.2.4 Lotte World Hotel, Seoul)

R-4



107

R-4

2017 Global Rally for the Peaceful Reunification of the Korean Peninsula  
(Seoul World Cup Stadium: 80,000 people, 2017. 11.11)

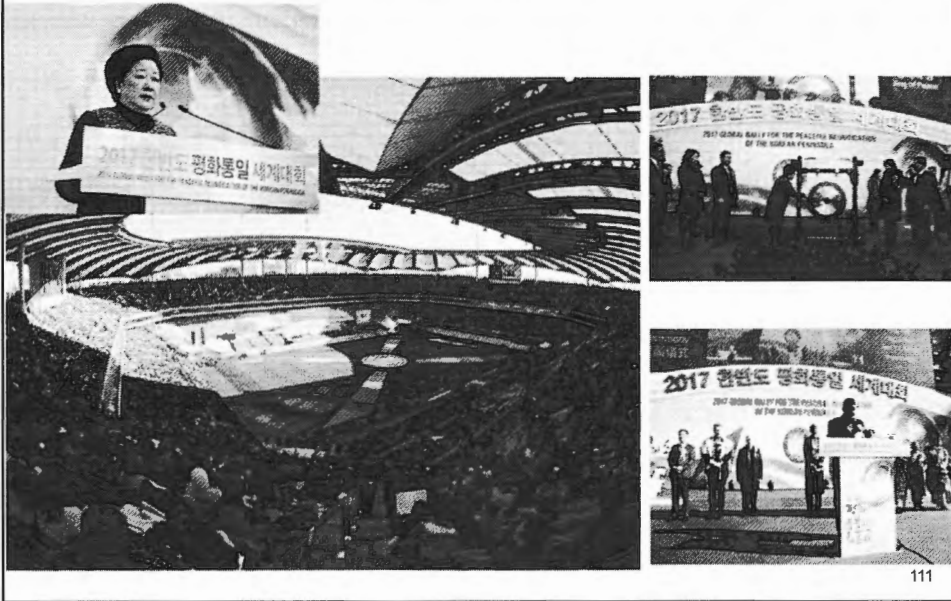

R-4





R-4

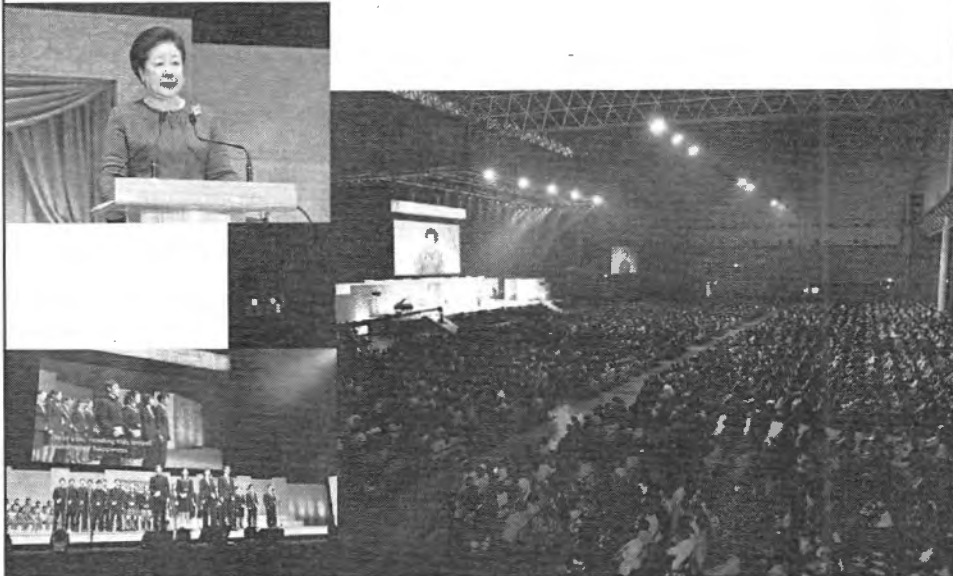

Hyo Jeong Culture Festival in Kanagawa (2017.10.15)

113

R-4

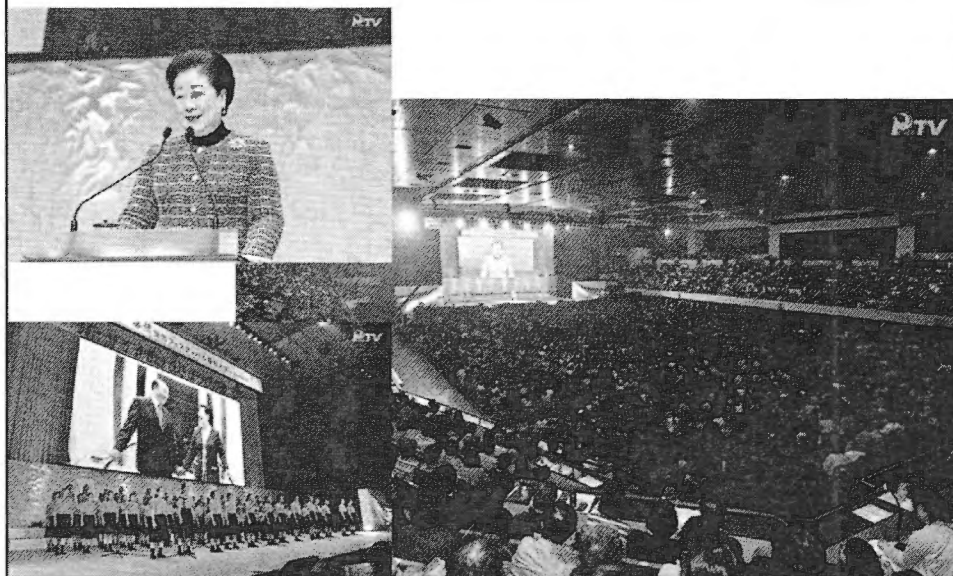

Hyo Jeong Culture Festival in Nagoya, 2017.11.16

114



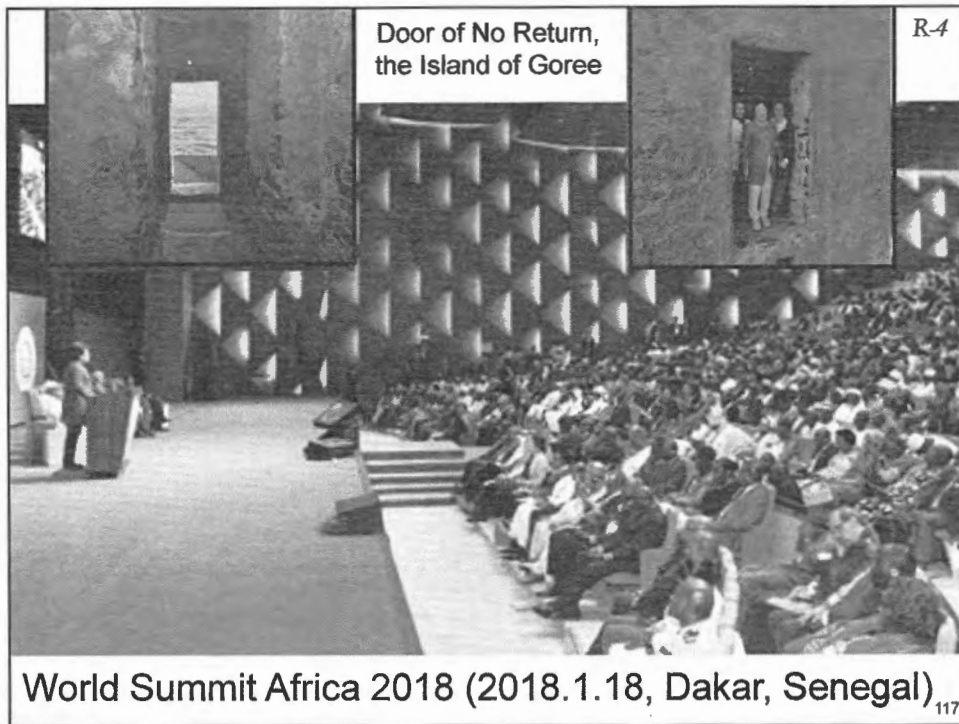

R-4

Should we put the mission of salvation of all humanity on True Parents' shoulders alone?



Do they deliver gifts only once a year?

119

R-4

What is the most precious gift to all humanity?



It is the Manual for the Registration as CIG citizens.

116

It is to bring victory as the Heavenly Tribal Messiahs by establishing the family Four Position Foundation.

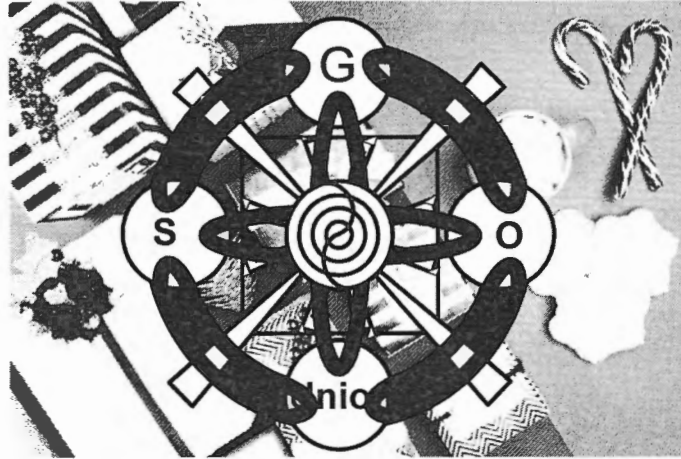

By expanding the foundation of Heavenly Tribal Messiahship, we will save the society, nation and the world.

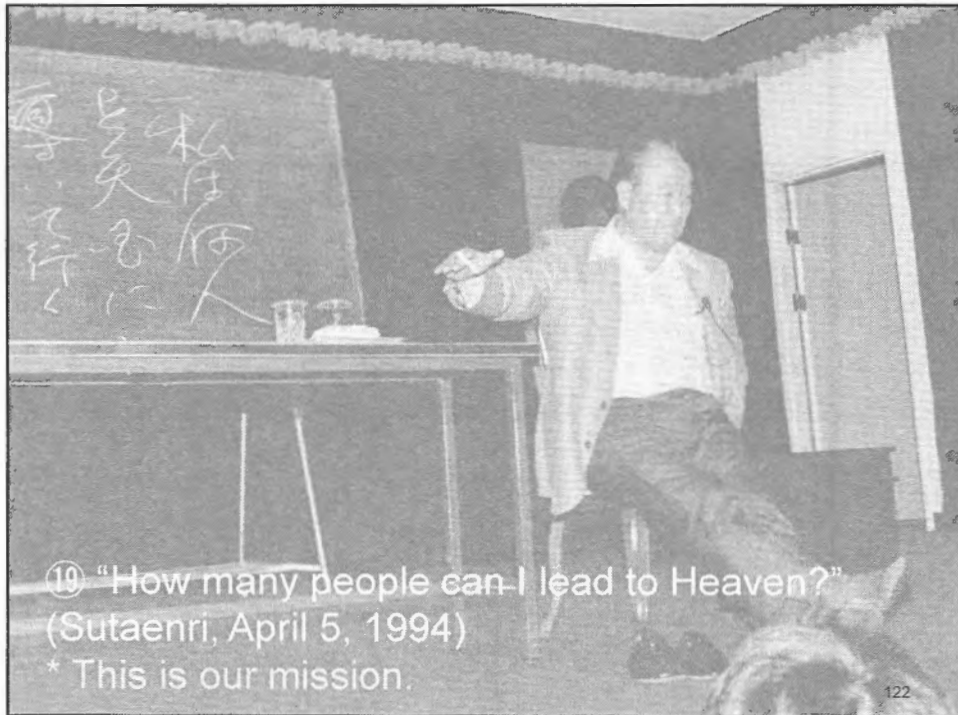

"I want to see your determination at this rally." R-4



2018 Rally for the Hopeful March Forward of Family Federation for a Heavenly Korea (2018.2.22) 123

R-4

⑮ "You can convey the Word with a desperate heart, having the proper attitude centered on my (True Parents') name and having the *Shimjeong* of a parent to save them (people)... When you shout it out, it spreads out as you shout. When people hear you, they will respond to you and you can reap the harvest. Don't lose this time. ... Since we can welcome a new age in which we can do new activities with a new attitude, I hope that you will march forward with a hundred times more courage. ...

124

You must deepen and expand your *Jeongseong* (sincerity and devotion) more than in any past ages. ... Miracles will occur. Things you only dreamed about can happen. ... If you invest your efforts with *Shimjeong* that is more than the *Shimjeong* of loving your nation, your tribe, or your brothers, and having the same heart as mine (True Parents'), Heaven will give great results to you and your tribe. ... That will happen without fail." (2008.1.2)



General Assembly for CIG Leader (2018.2.25, Cheongseong Wanglim Palace, Cheongpyeong Training Center) 126



**“Let’s go back to our homeland  
with True Parents”  
(1967.7.3)**